



FIELD DAY HF ANTENNAS

Lew Thompson

W5IFQ

7 JUN 2022

Purpose of Field Day

- Demonstrate the ability to set up an Amateur radio station in the field on emergency power and communicate effectively over all of CONUS.
- Increase public awareness of Amateur Radio
- Operator Training
- Recruitment of new hams
- Have fun



Field Day 2022

When: 25 – 26 June, 1 PM Saturday till 1 PM Sunday

Where: Red Cross building – 2218 Pershing Ave.

Operations Details:

- **Four stations:**
 - **TCARES Emergency Trailer – HF Multi-mode + Emergency Power**
 - **VHF/UHF Multi-mode building A**
 - **HF Multi-mode (CW and SSB) building B**
 - **GOTA (Get on the Air) – HF SSB**
 - **Designation – 3A STX**
 - **Operating spaces are air-conditioned!**
- **Meals**
 - **Saturday Lunch – Pizza**
 - **Saturday Evening - BBQ**

HF Propagation Modes

- Free Space – Line of site
- Ground Wave – Follows Earth's curvature
- Ionospheric Skip
 - Long Distance with a “dead-zone”
 - NVIS (Near Vertical Incidence Sky Wave)

Optimizing HF Communications

- Ionospheric propagation
 - Frequency selection (MUF for target area)
 - Other propagation factors
- Antenna design
 - **Correct directivity pattern**
 - Provide usable impedance to RF transmitter

Long Distance Sky Wave

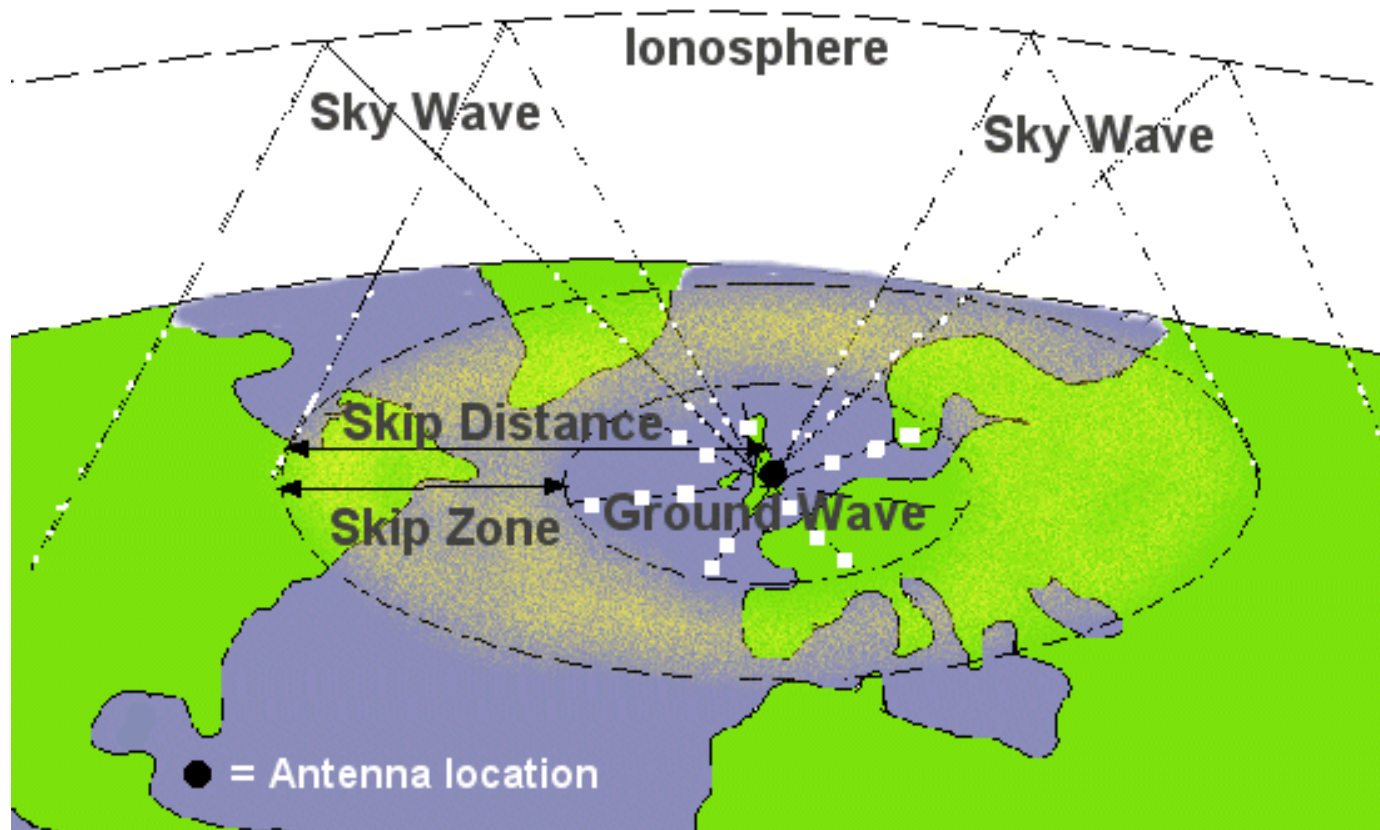

NVIS Propagation

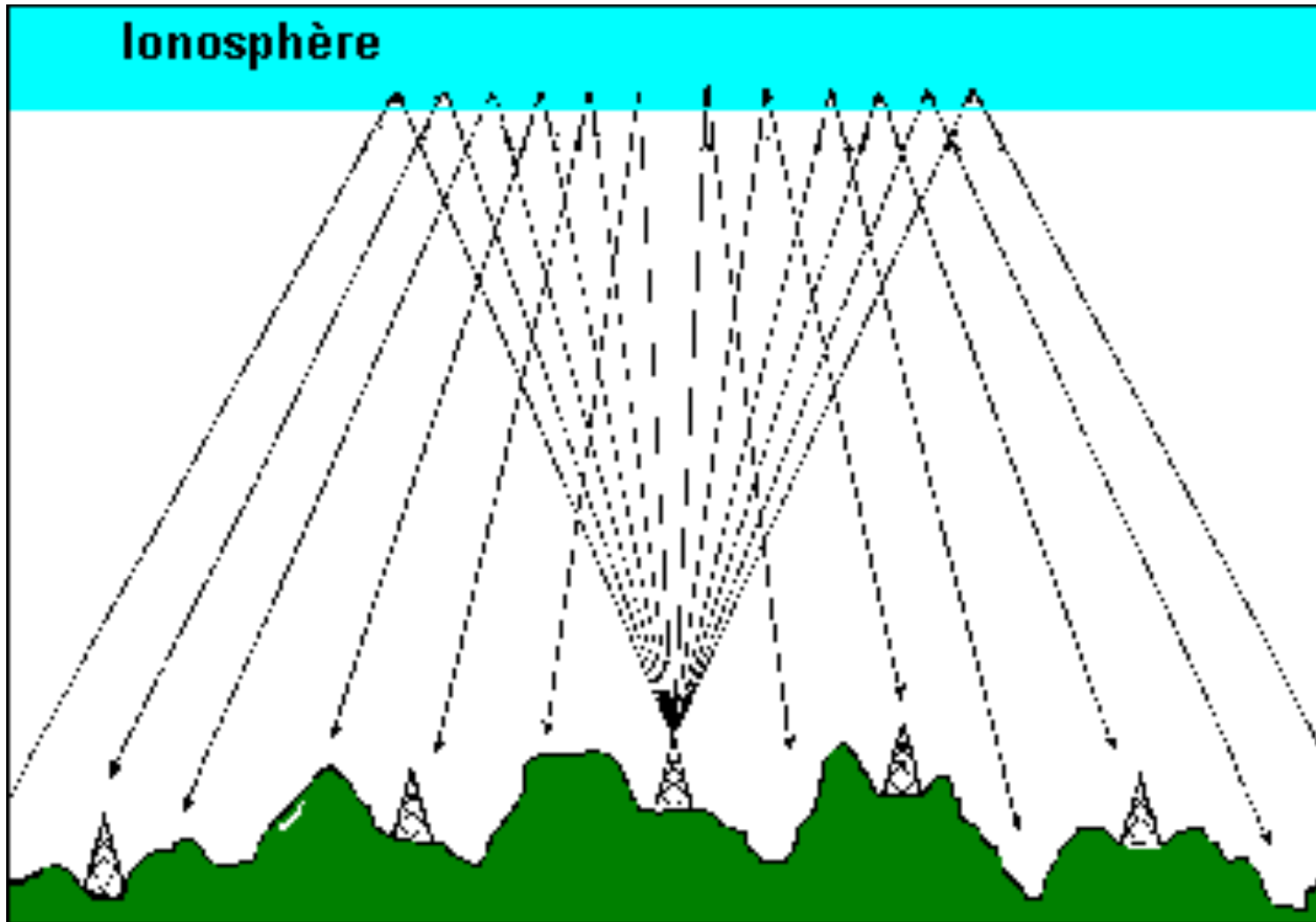

Dipole Height Versus Directivity

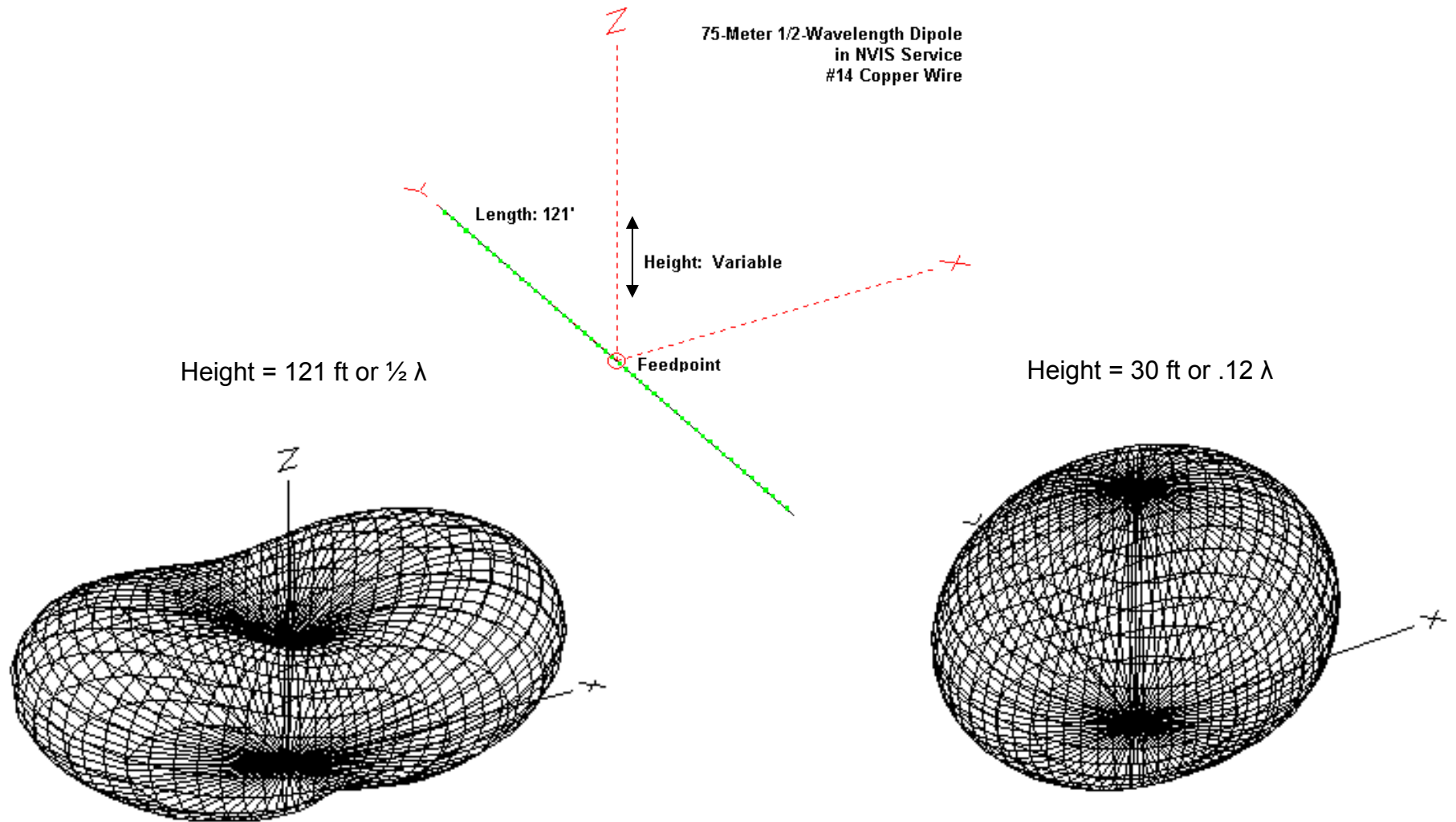

MARS Portable Dipole

Inverted-V:

Apex – 32 ft.

Length – 65 ft.

End heights – 15 ft.

Wire - #14 AWG

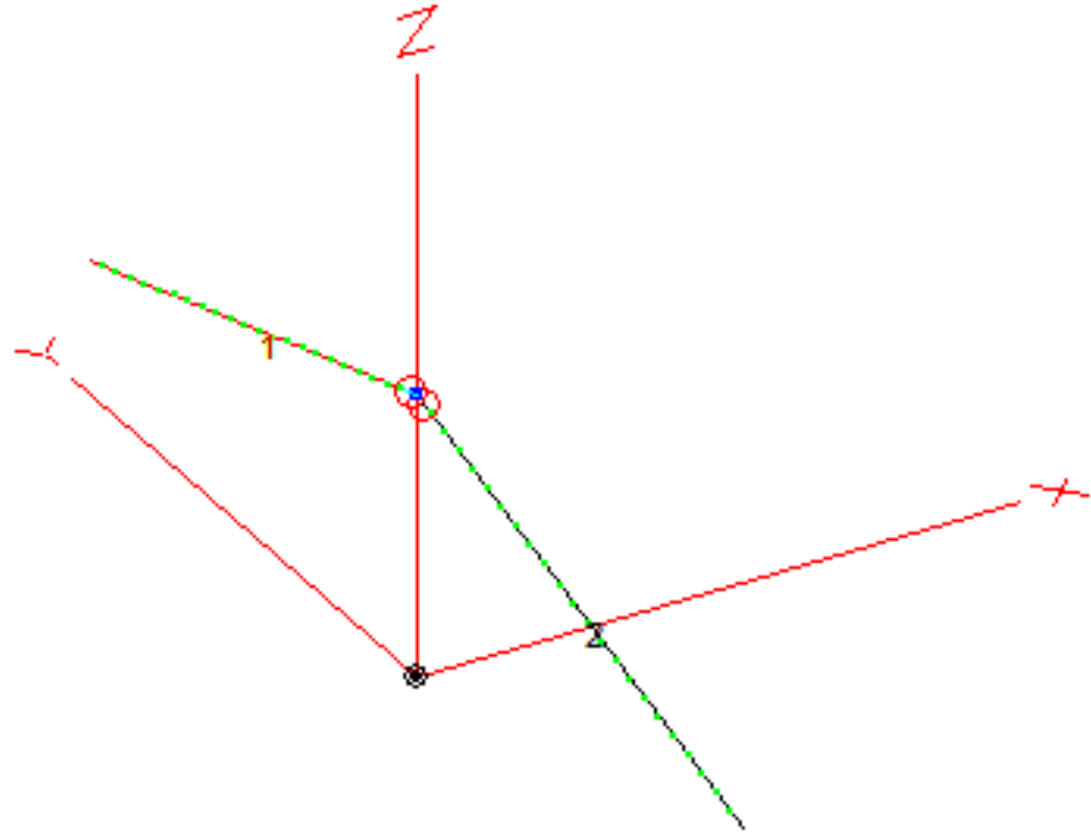

NVIS Performance

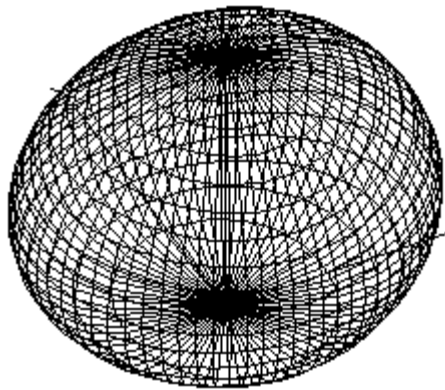

3.8 MHz

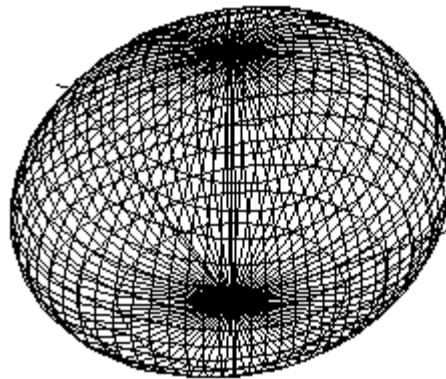

5.2 MHz

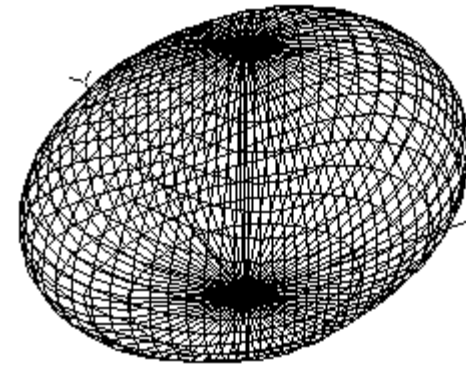

7.2 MHz

Skip Performance - BAD

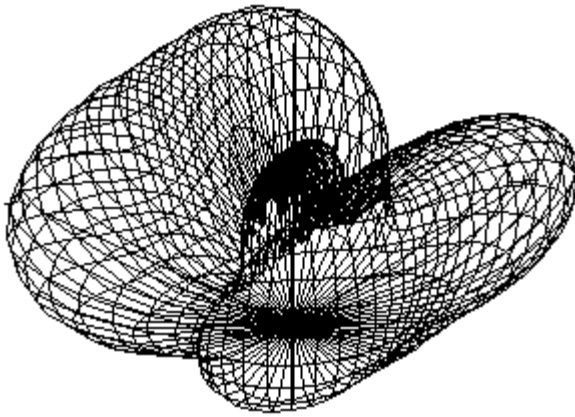

14.3 MHz

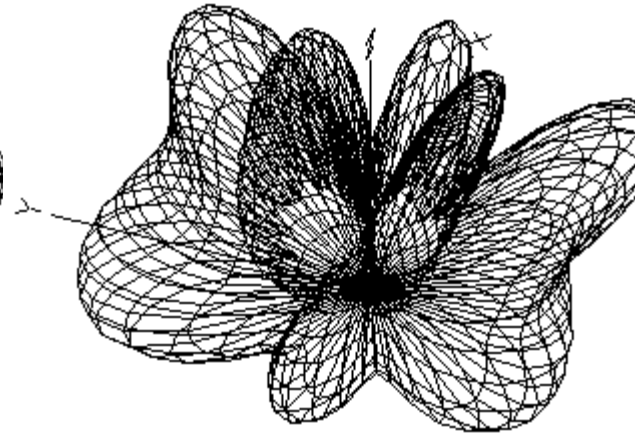

21.4 MHz

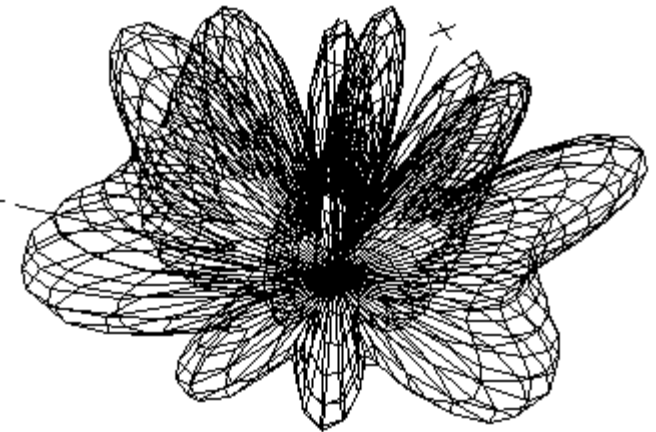

28.4 MHz

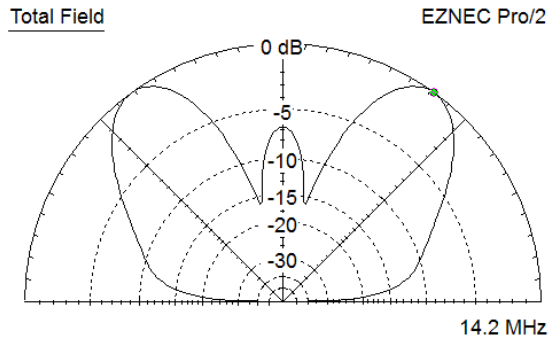

Poor Take-off Angle

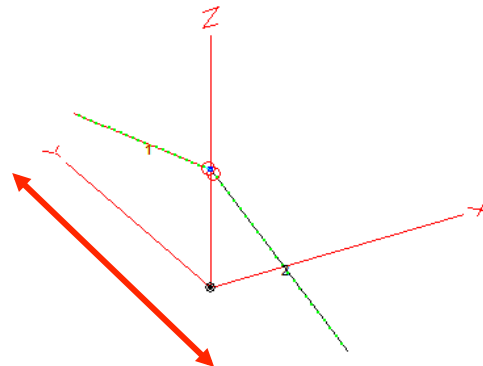

Note: Maximum gain
Off ends of wires

Corrections To Directivity

(Shorten each leg from 65 ft. to 18 ft.)

Inverted-V

Height – 32 ft.

Leg Length – 18 ft.

Same angle as full dipole

Original dipole folded back to length of 18 ft. on each leg.

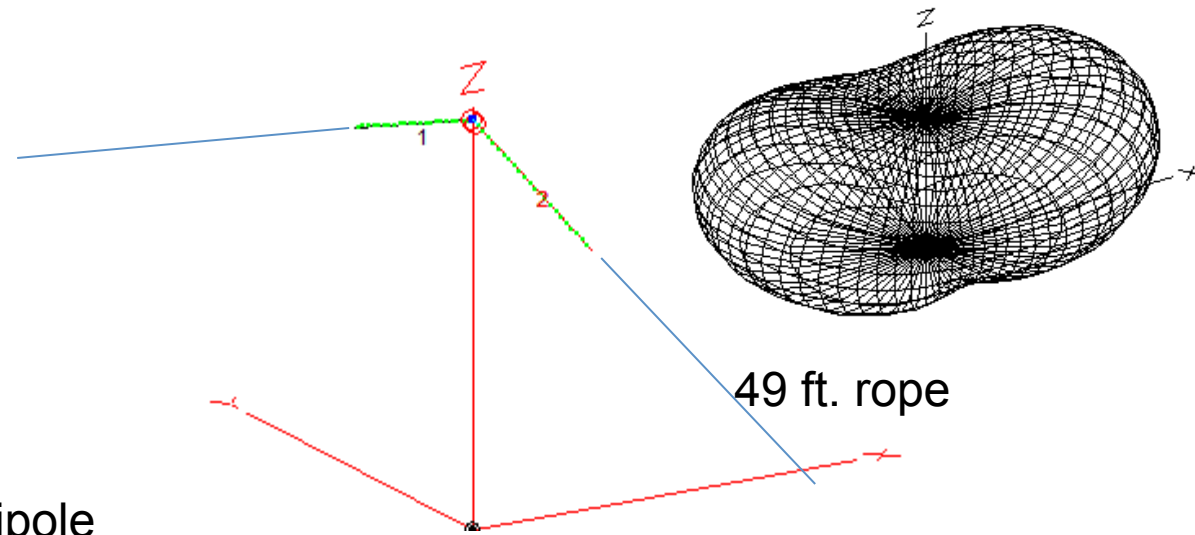

Total Field

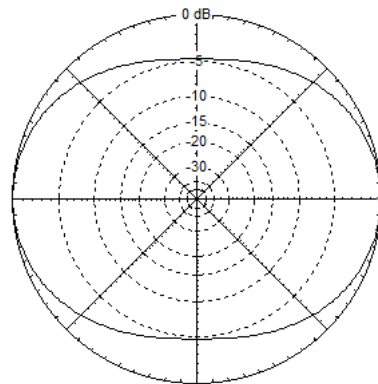

EZNEC Pro/2

14.3 MHz

Total Field

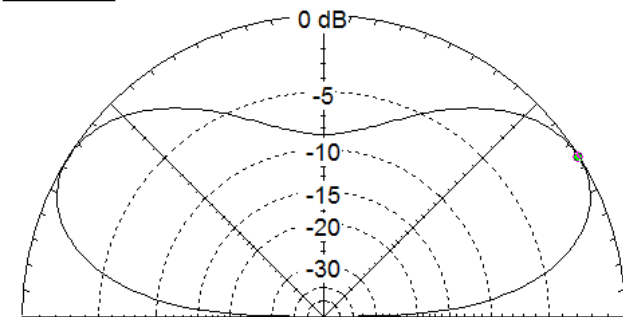

EZNEC Pro/2

14.3 MHz

12

Skip Performance – 20m dipole

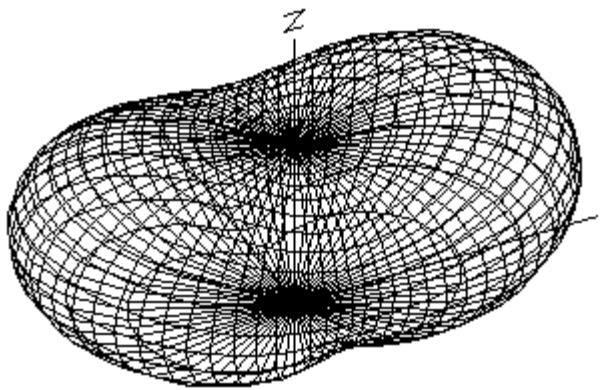

14.3 MHz

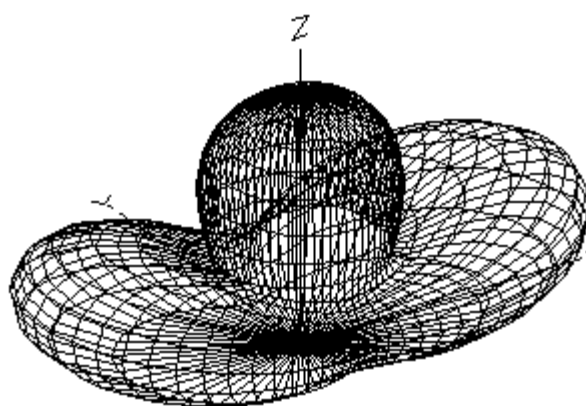

21.4 MHz

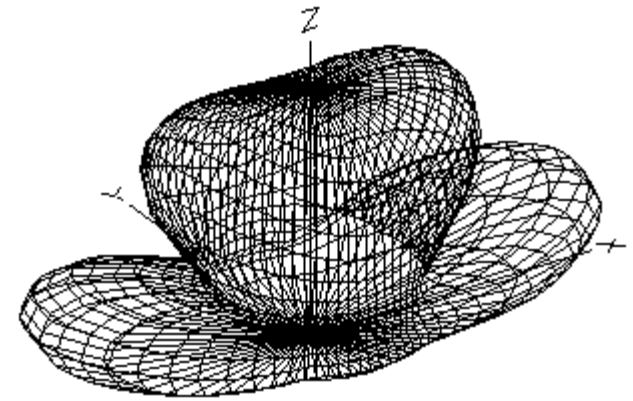

28.4 MHz

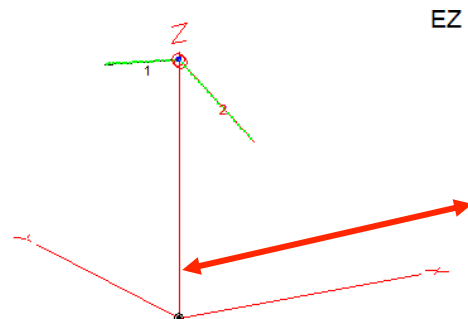
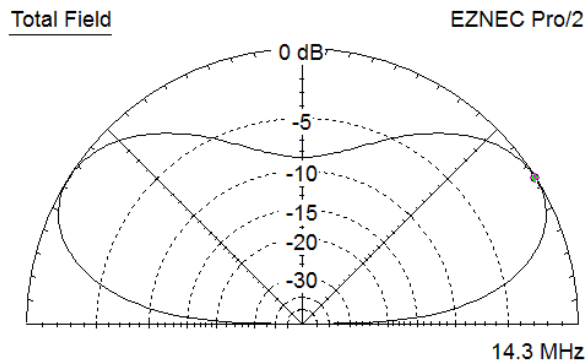

Note: Maximum gain
Right angle to wires

Option 2 – Adjustable “Reel” Dipole



L

1 MHz

Frequency

Vertical Antenna 1 Description

- Auto-tuned vertical with ground radials
- Base height above ground – 2 ft.
- Vertical height – 23 ft.
- Vertical Type – Shakespeare 393 Marine SSB HF
- Ground Radial length (each) – 25 ft.
- Number of ground radials – 4
- Auto-tuner – ICOM AH-4

Original FD Vertical

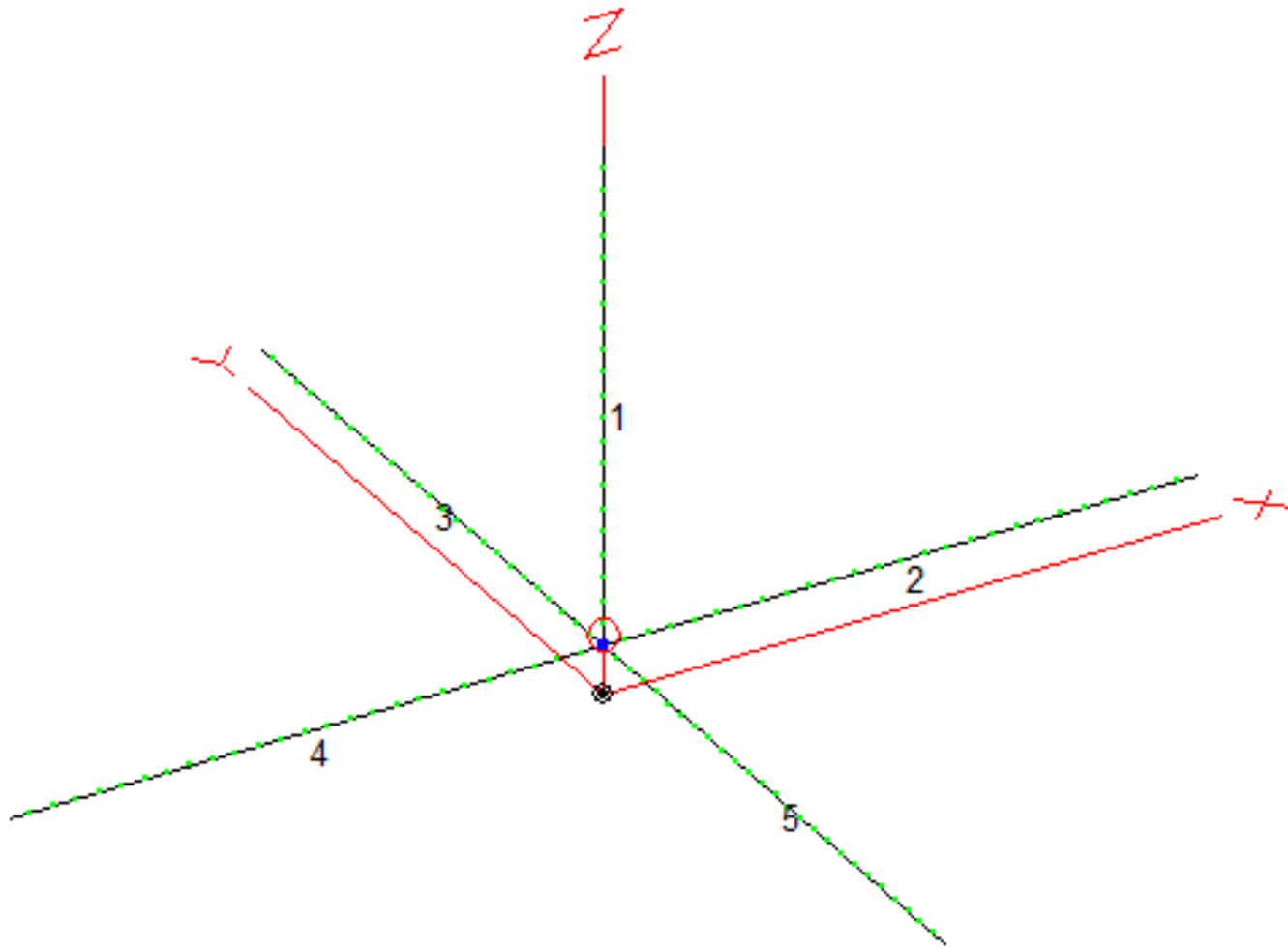

Vertical Antenna Pattern

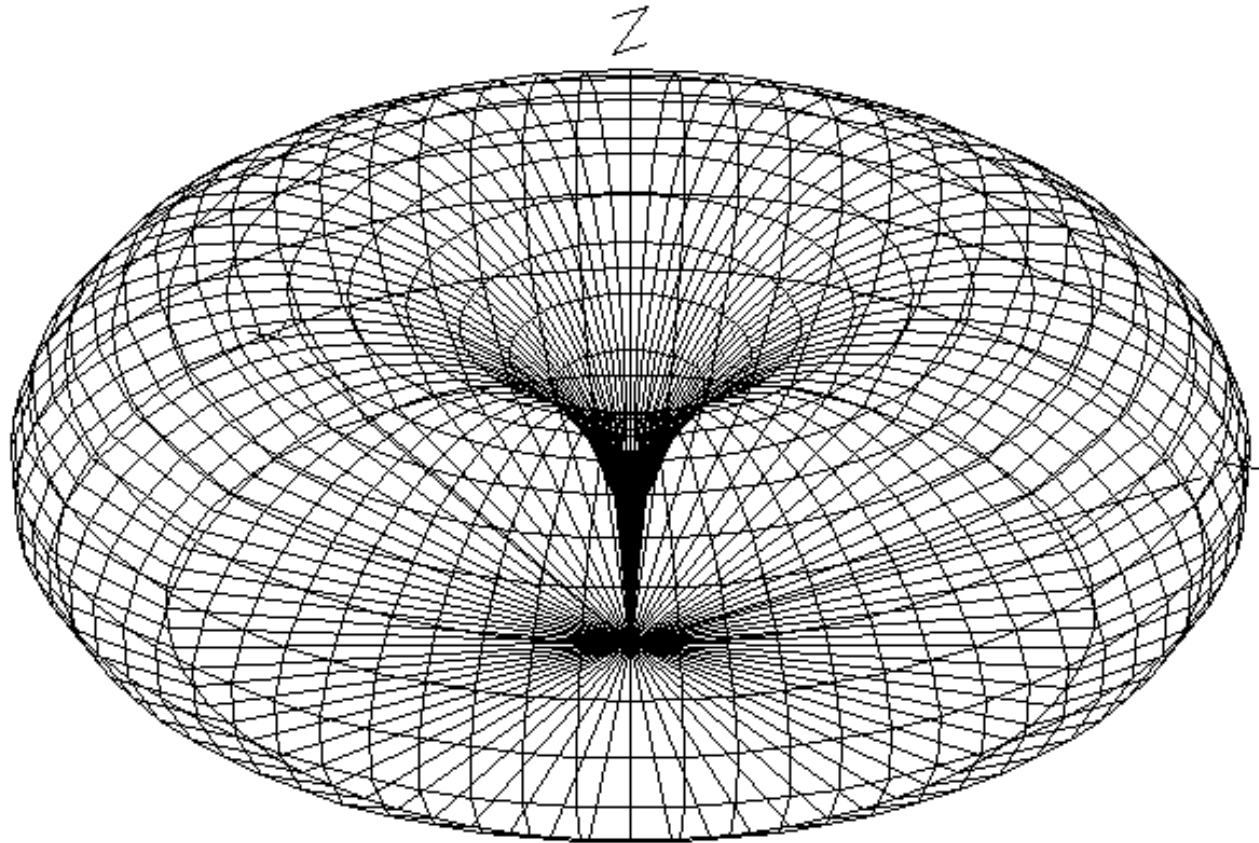

Other Vertical Antennas

(Tuned "TRAP" Verticals)

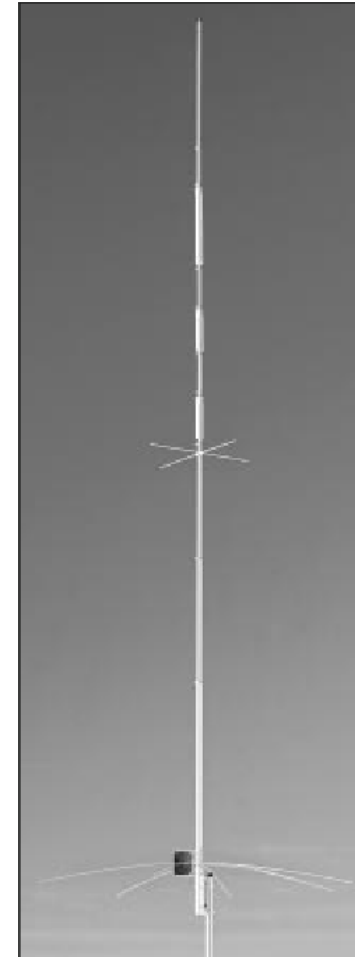
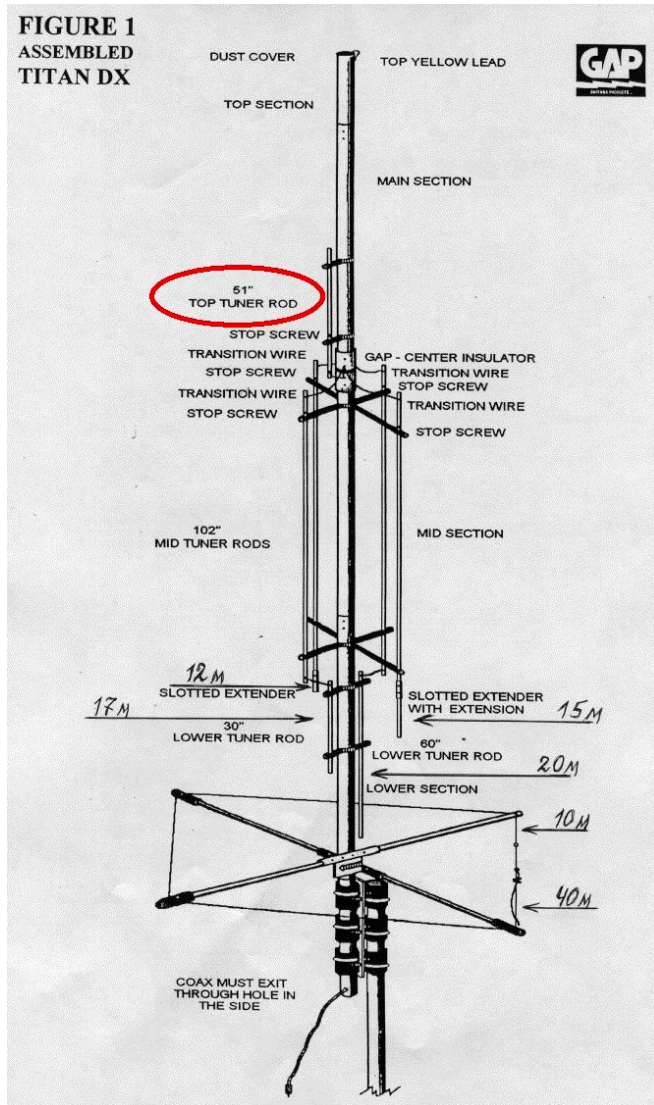

R7000

Optimizing HF Communications

- Ionospheric propagation
 - Frequency selection
 - Other propagation factors
- Antenna design
 - Correct directivity pattern
 - Provide usable impedance to RF transmitter

Special Tuning Elements

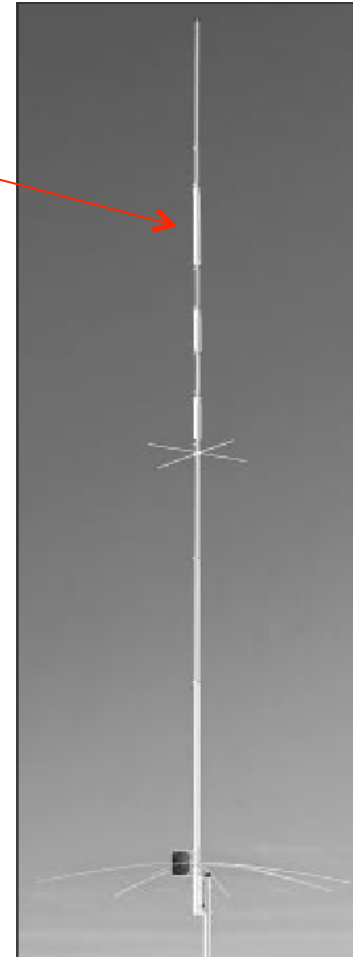
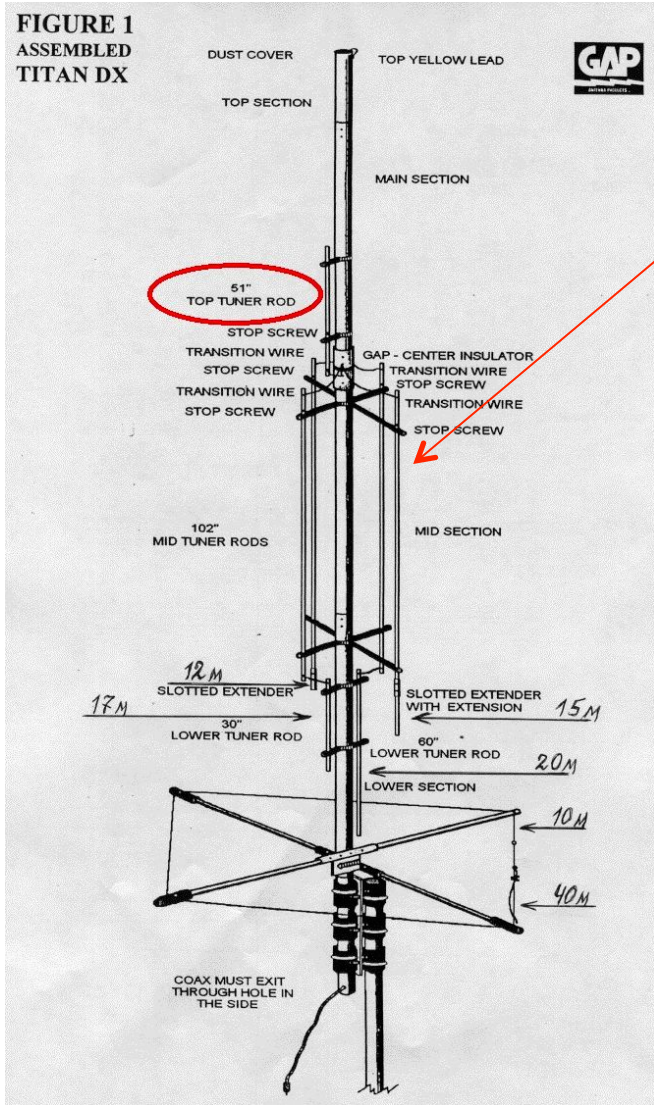

R7000

Half Wave Dipole

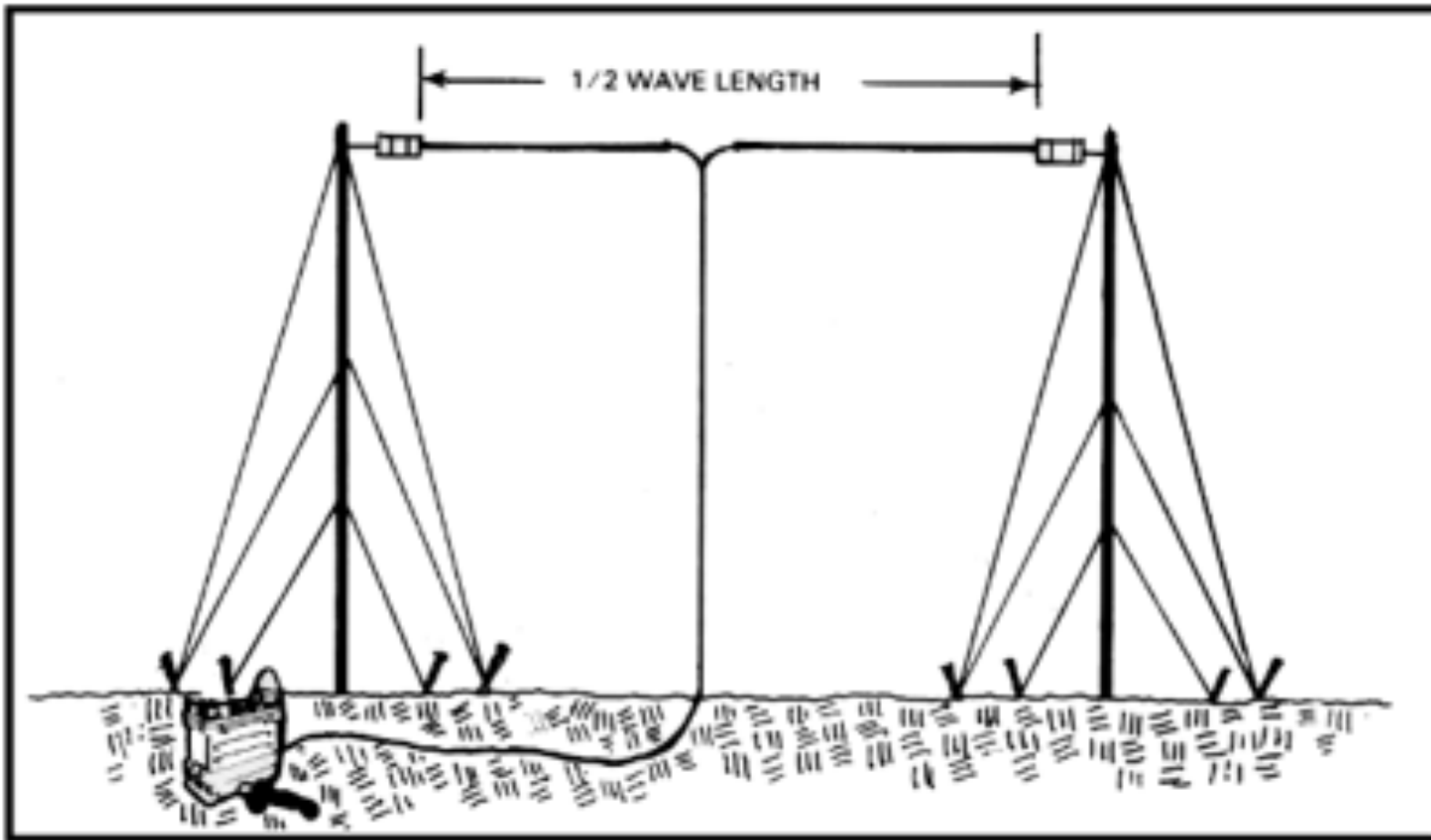

Inverted-V Half-Wave Dipole

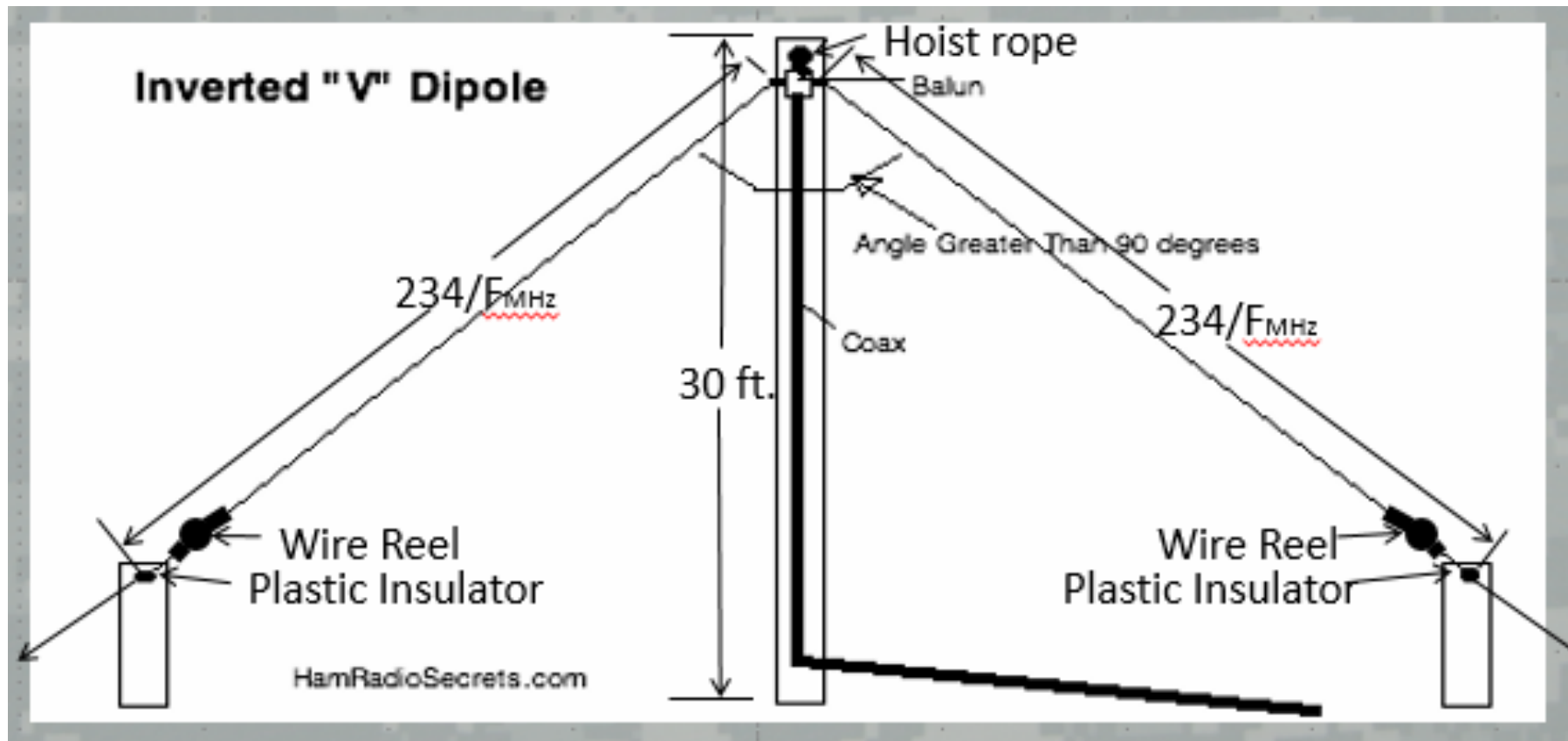

Adjustable “Reel” Dipole

- Adjust length for one-half wavelength
- Impedance will be close to 50 ohms and therefore no tuning required, or internal HF rig tuner can make fine adjustments (<3:1)



TUNER AT ANTENNA

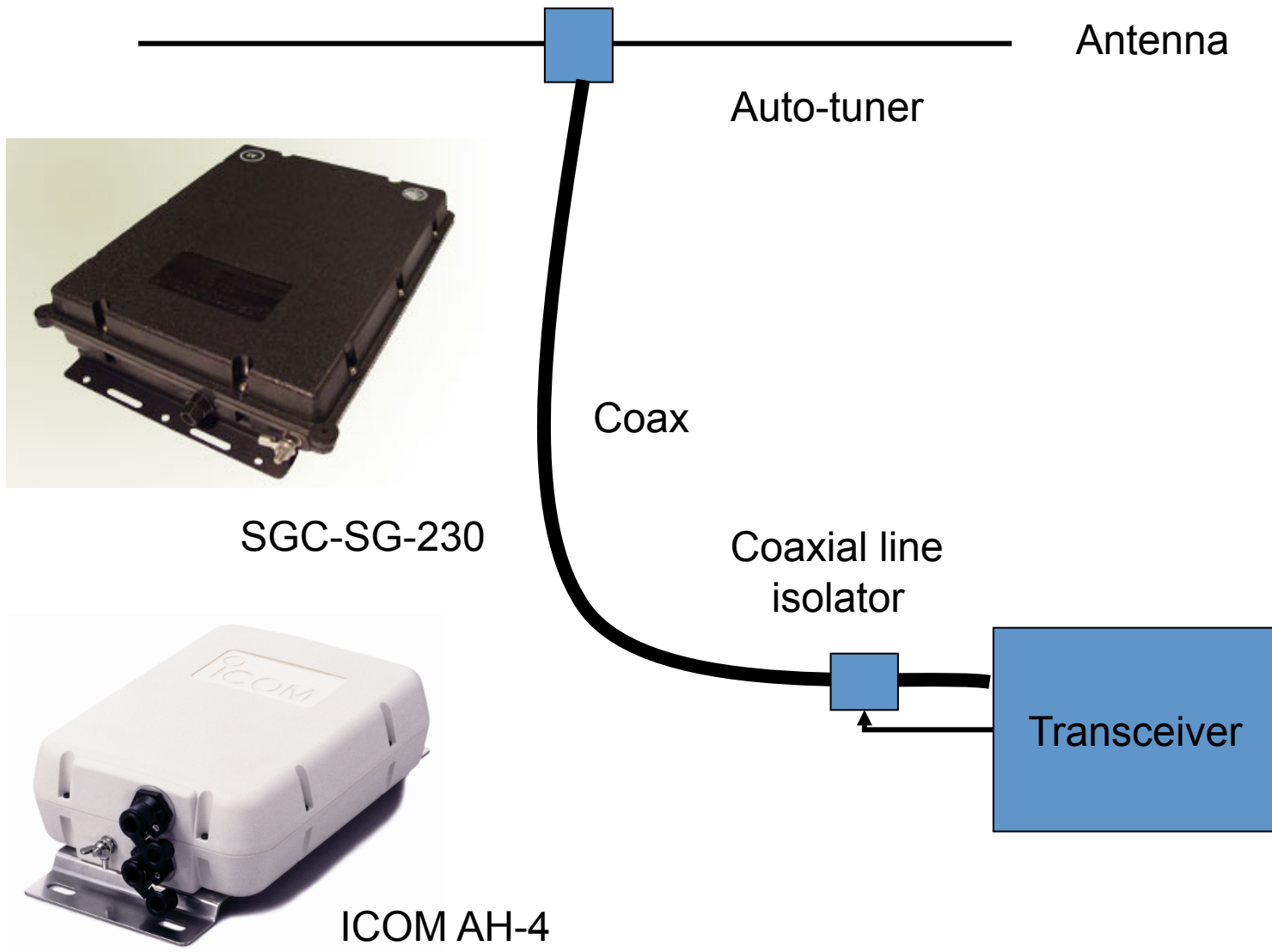

Auto-Tuner Near Antenna

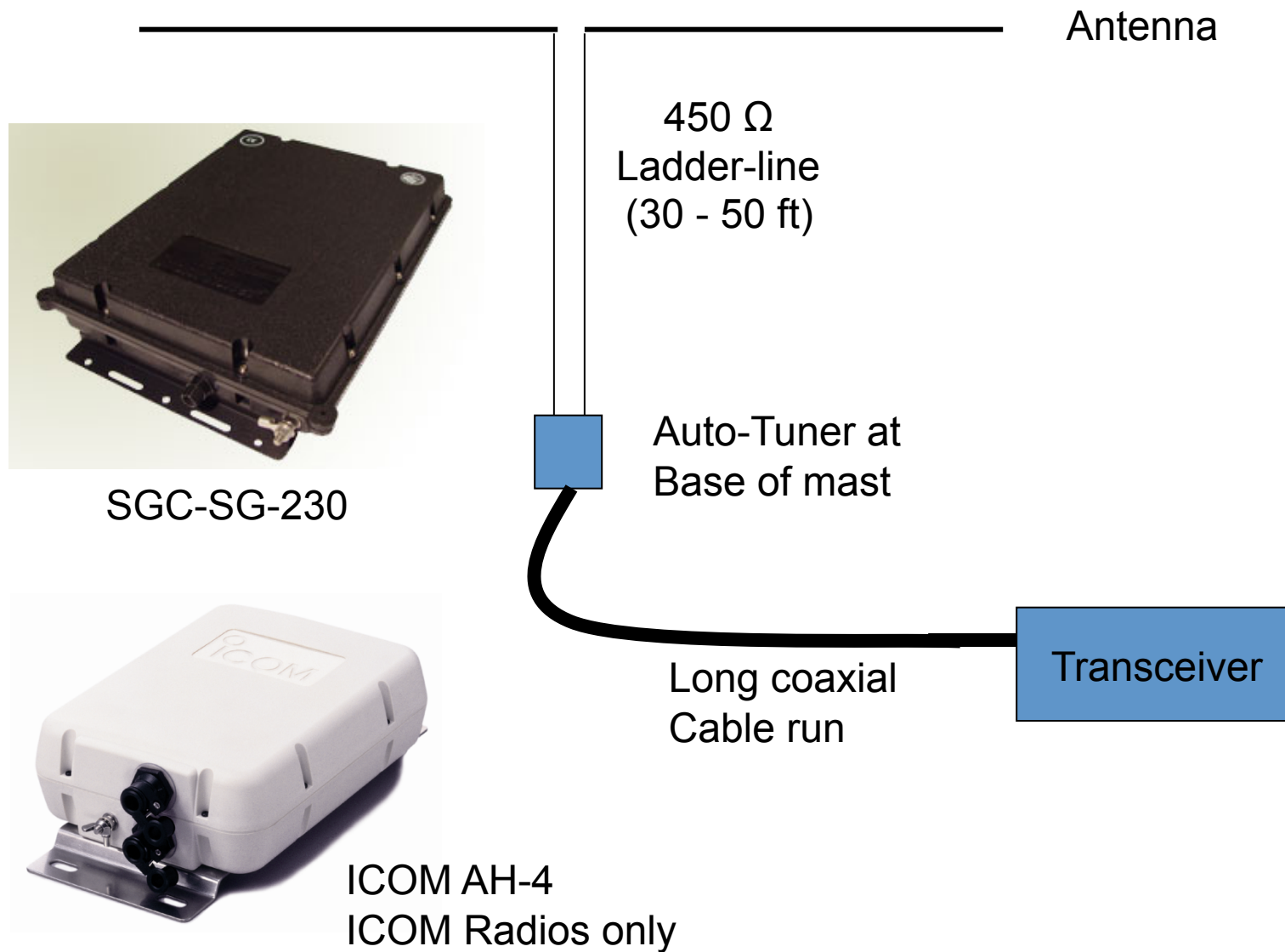

Station Details From Station Captains

- CW/SSB – Lew W5IFQ
 - ICOM IC-756Pro3 (Bencher paddle)
 - Desk Mic
 - Multiple Vertical Antennas
- TCARES Trailer – Rex K8REX
 - Auto-tuned Dipole
 - ICOM IC-7100
- GOTA – Ronny KC5EES
 - ICOM IC-706Miig with auto tuned dipole
- VHF/UHF – Jeff N5MNW