



Directional Antennas & HF Long-Range Propagation (two part series)

Lew Thompson

W5IFQ

4 MAR 2025

Objectives

- Introduce long-range ionospheric skip sky-wave propagation theory and practice.
- Discuss suitable HF antennas for long-range propagation

Outline

- Introduction to Long-Range HF Propagation
- Antenna Types
 - Verticals
 - High Dipoles
 - Yagi's
- HF Skywave Propagation theory and Prediction
 - Theory
 - Prediction Program – VOACAP
 - Beacons

HF Propagation Modes

(3 – 30 MHz)

- Free Space – Line of sight
- Ground Wave – Follows Earth's curvature
- Ionospheric Skip
 - Long Distance with a “skip-zone”
 - NVIS (Near Vertical Incidence Sky-Wave)

Long Distance Sky Wave

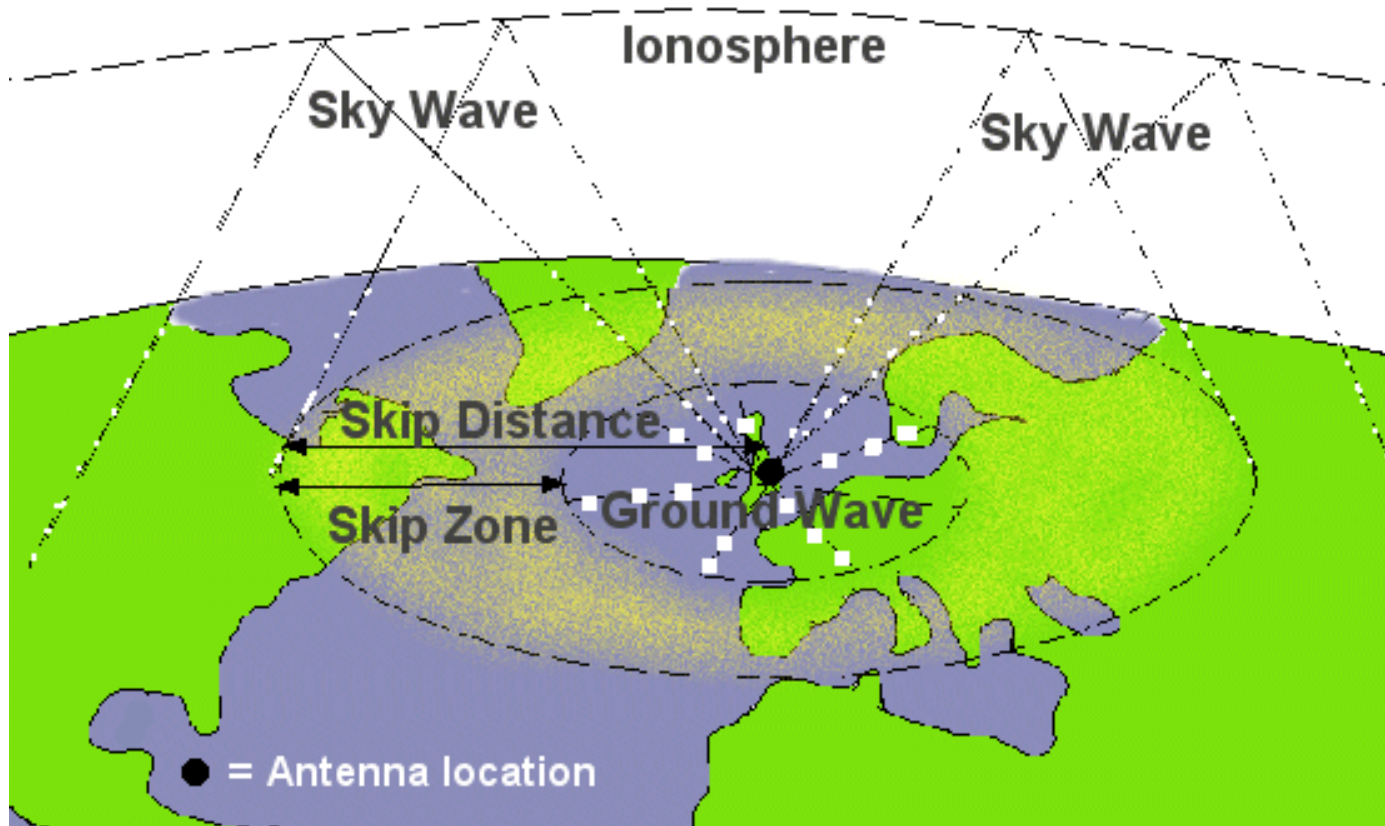

HF Sky-Wave Antennas

- To conduct successful long-range HF sky-wave communications, all antennas must generate low take-off angle (TOA) RF emission.

TYPICAL LONG-RANGE PROPAGATION

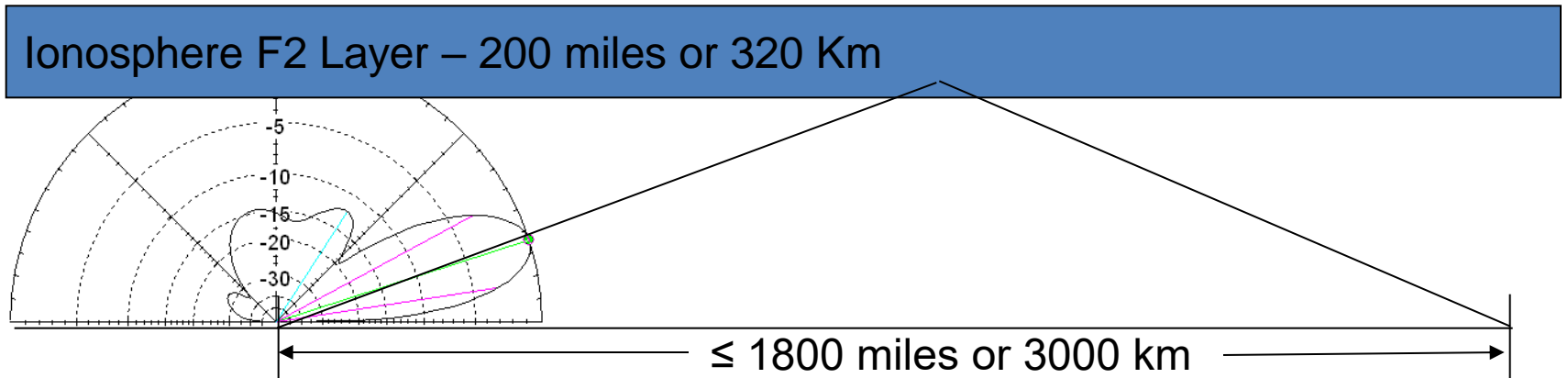

Both F2 & E layers propagation can be involved in multiple reflection circuits.

TOA Versus Range

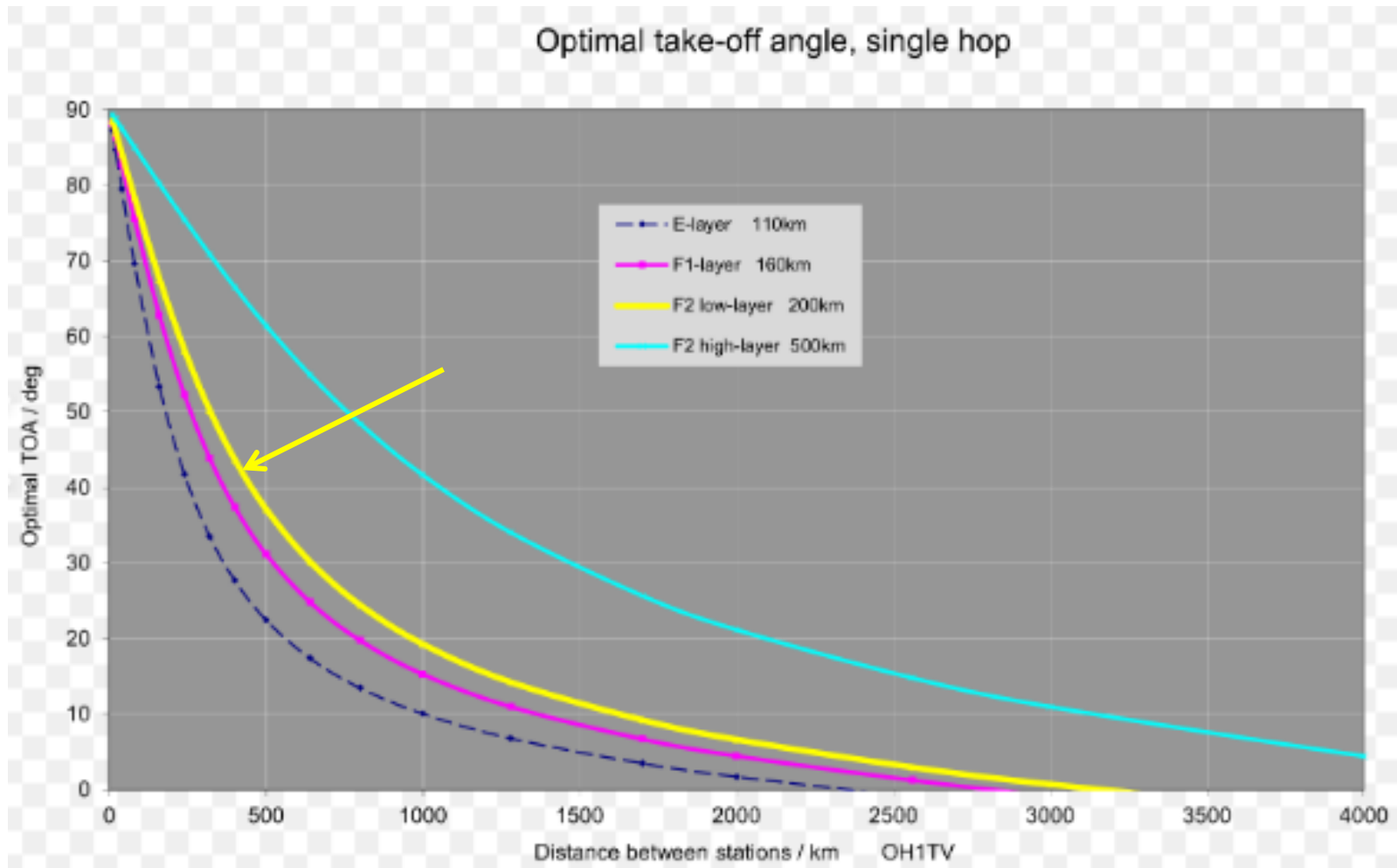

Dipole Height versus Range

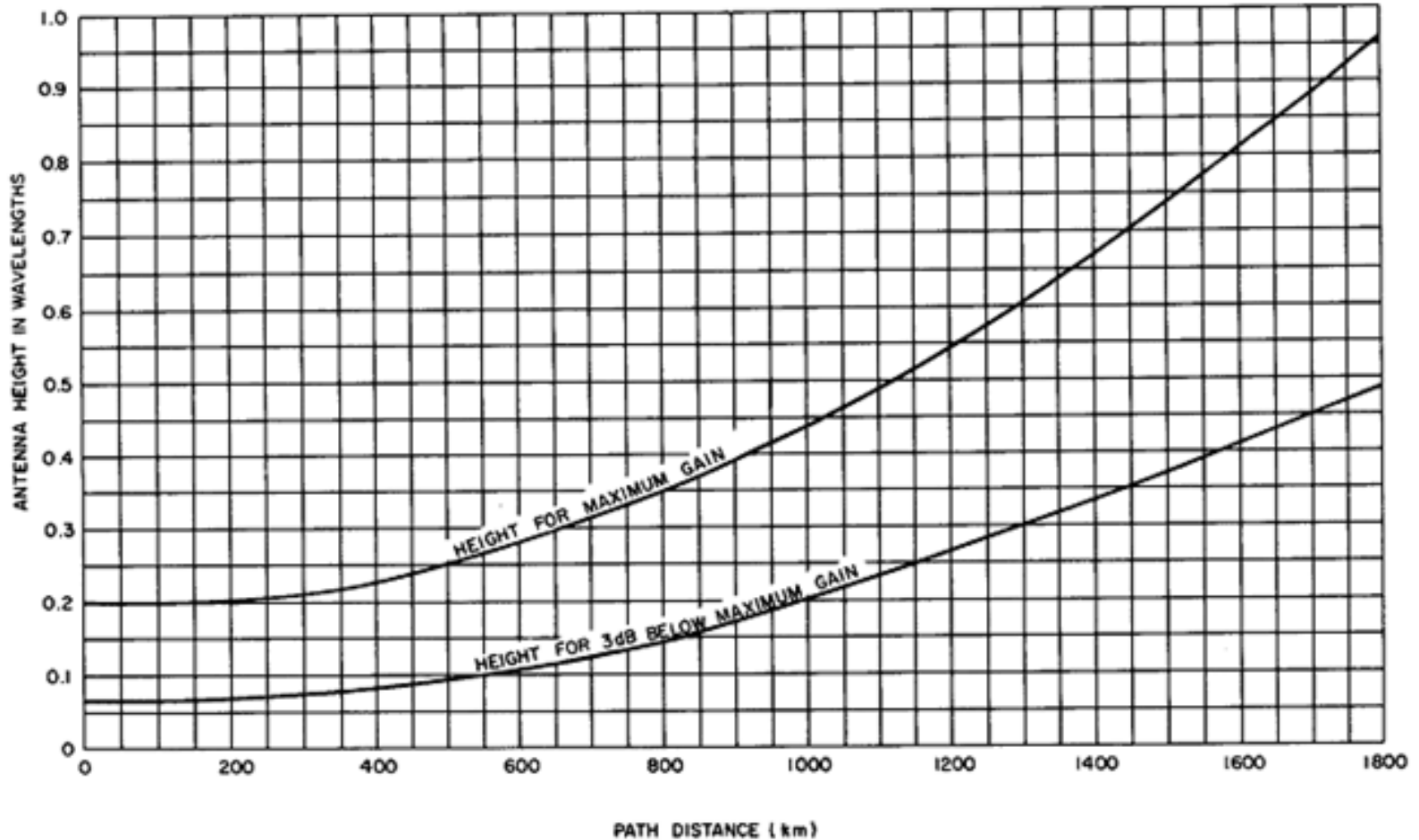

Figure 5-3. Approximate height of half-wave dipole for best F2 layer propagation.

HF Sky-Wave Antennas

- The TOA is a function antenna type and operating frequency and can include:
 - Verticals
 - High Dipoles (one-half wavelength or higher)
 - Yagi's
- In addition, all antennas must present a load impedance of about 50 ohms to the rig's transmitter to radiate efficiently using one of the following techniques:
 - Rig internal auto-tuner (<3:1 SWR)
 - External tuner or auto-tuner
 - Special tuning elements incorporated in the antenna.

HF Vertical Antennas

- The HF vertical antenna type, either ground mounted or elevated naturally generates a low TOA signal ideally suited for long-range sky-wave communications.

Vertical Antenna Pattern

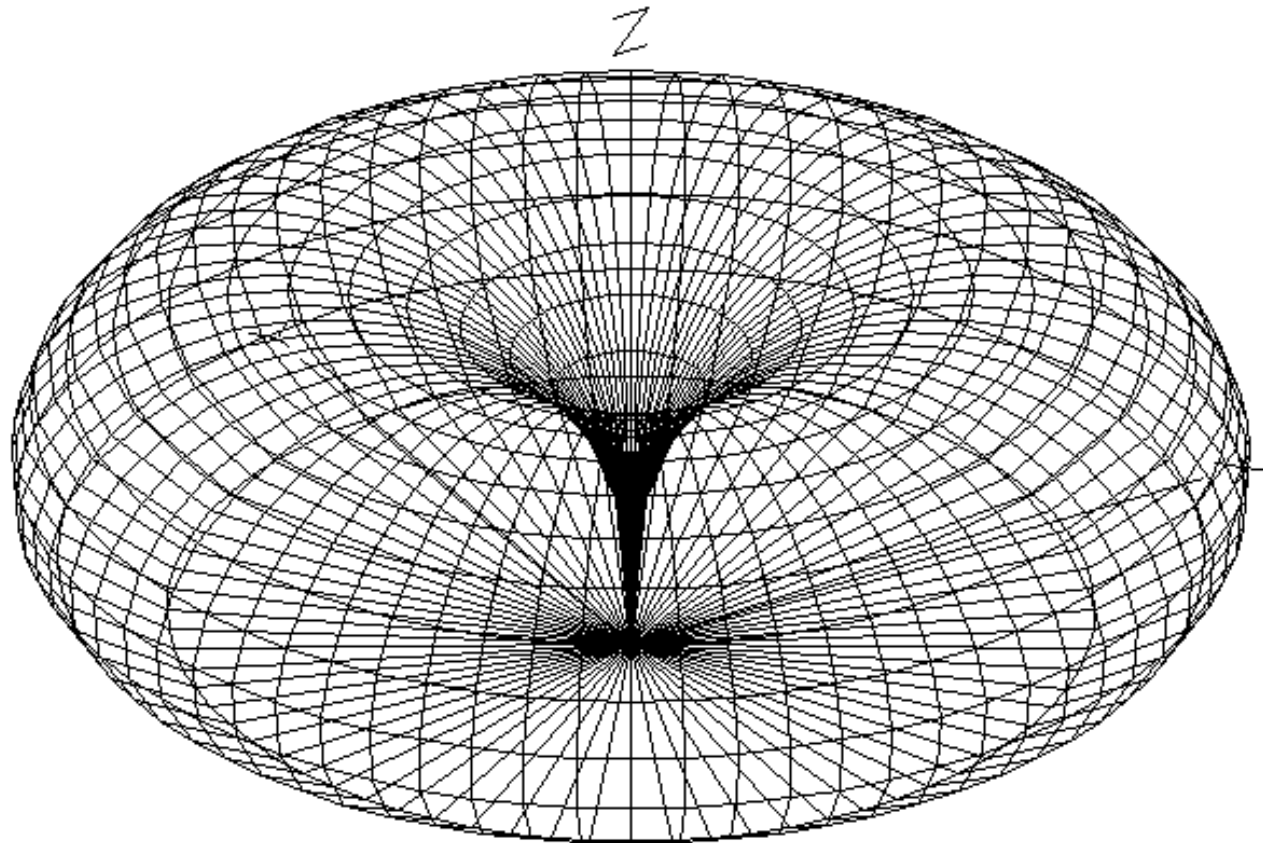

Marine Vertical

(Shakespeare 393 Marine SSB HF)



ICOM AH-4
Auto-Tuner

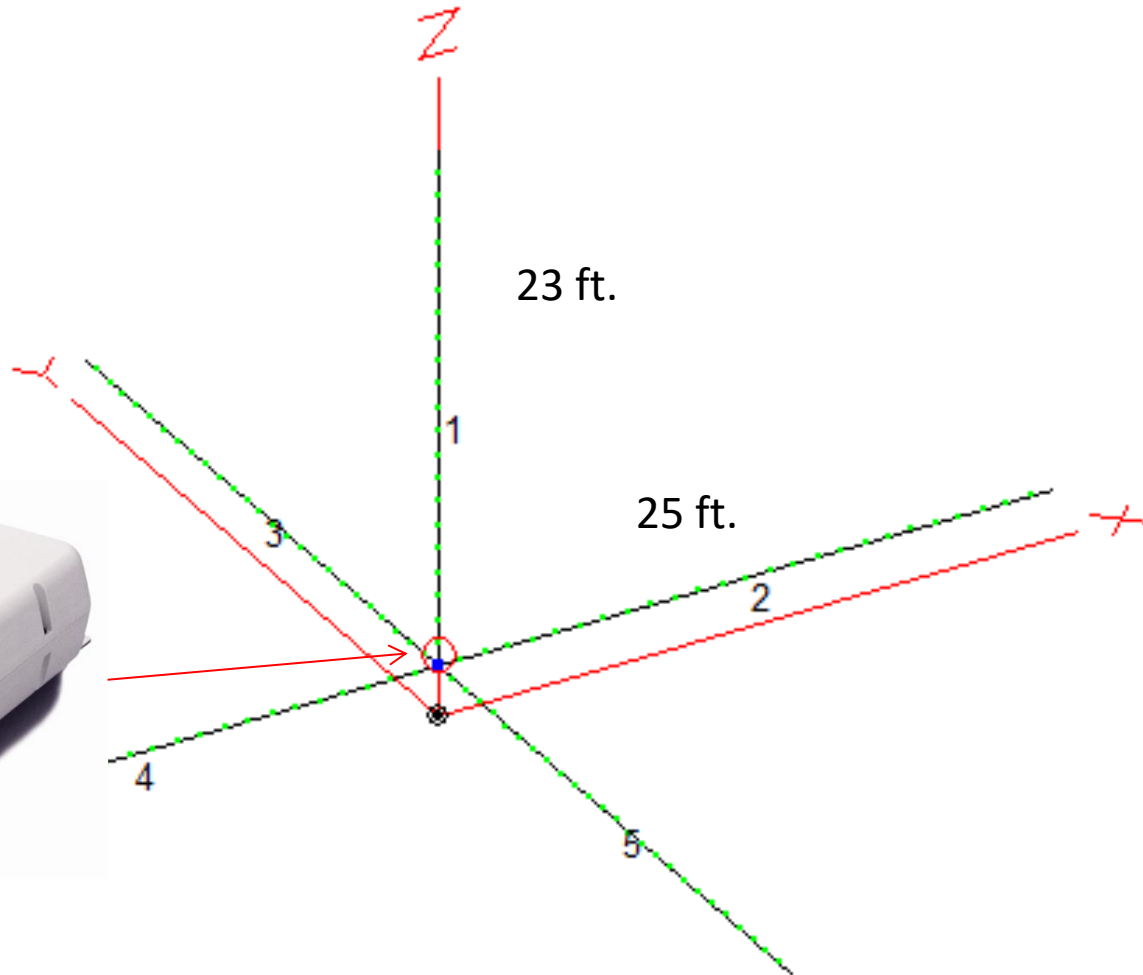

Special Tuning Elements

FIGURE 1
ASSEMBLED
TITAN DX

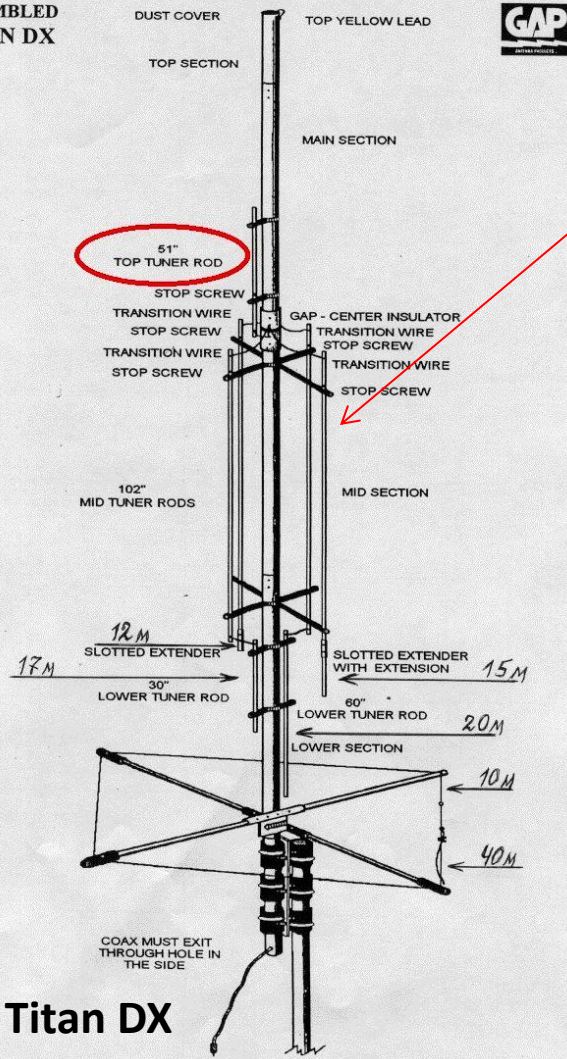

Gap Titan DX



R7000

High Dipole Antennas

- A horizontal dipole's directivity pattern changes dramatically with height above earth ground.
- At heights less than $\frac{1}{4}$ wavelength, the combination of the dipole and earth ground generate a virtual two element Yagi antenna with all the RF energy directed up. Suitable for NVIS.
- When the height exceeds $\frac{1}{2}$ wavelength, the dipole generates long-range directional pattern with a low TOA and maximum gain broadside to the dipole.

Dipole Height Versus Directivity

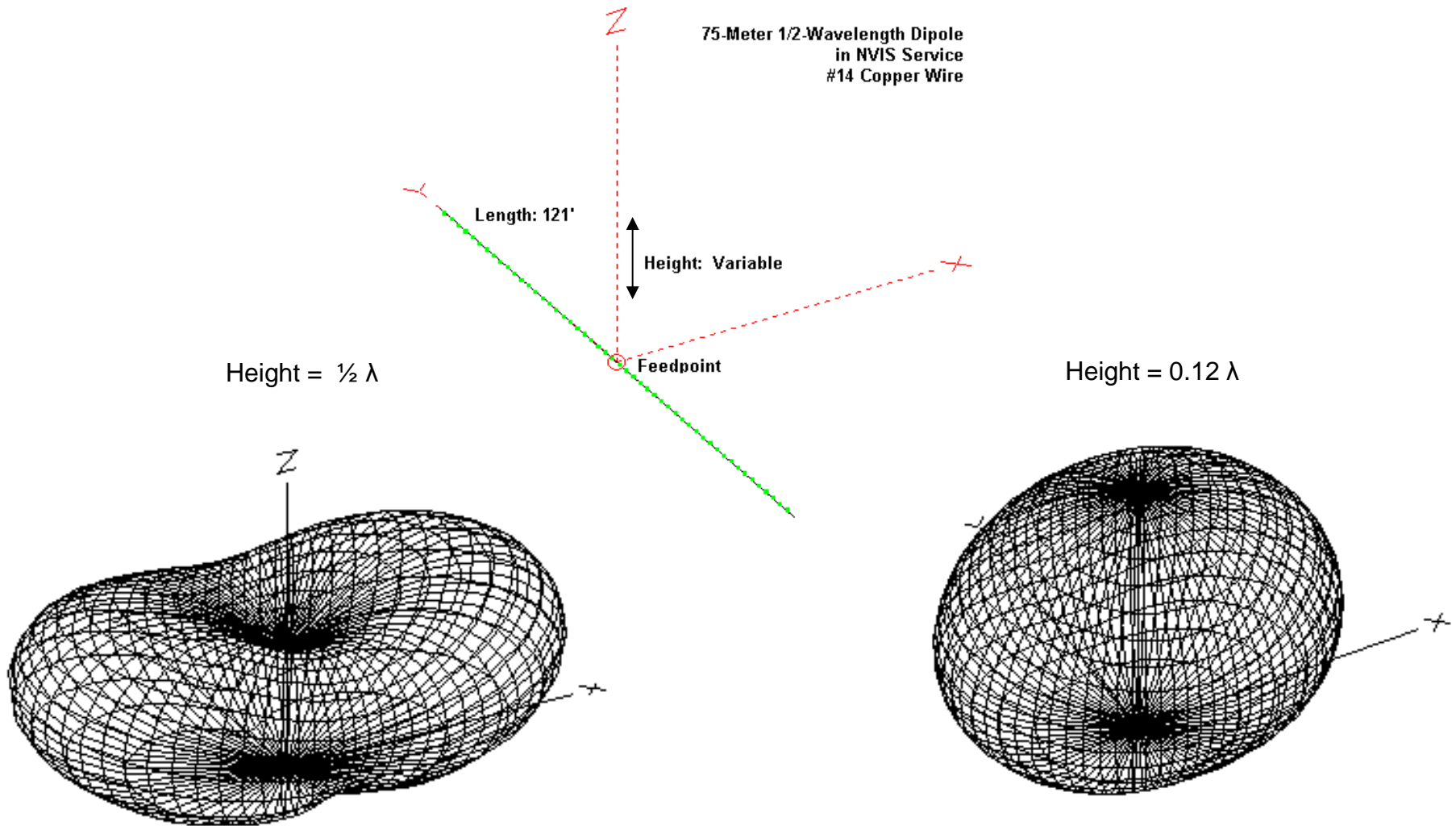

Yagi (Beam) Antennas

- Yagi's are multi-element **horizontally** polarized antennas whose parasitic elements enhance the horizontal directivity (azimuth) of the imbedded dipole.
- The Yagi must be at a height of $\frac{1}{2}$ **wavelength to achieve a low TOA**, just like the standard dipole.
- A rotor must be employed to rotate the Yagi to the desired azimuth.

Yagi Antennas



SteppIR DB-36 at 70 ft.



Hex Beam

Typical Yagi-Uda Antenna

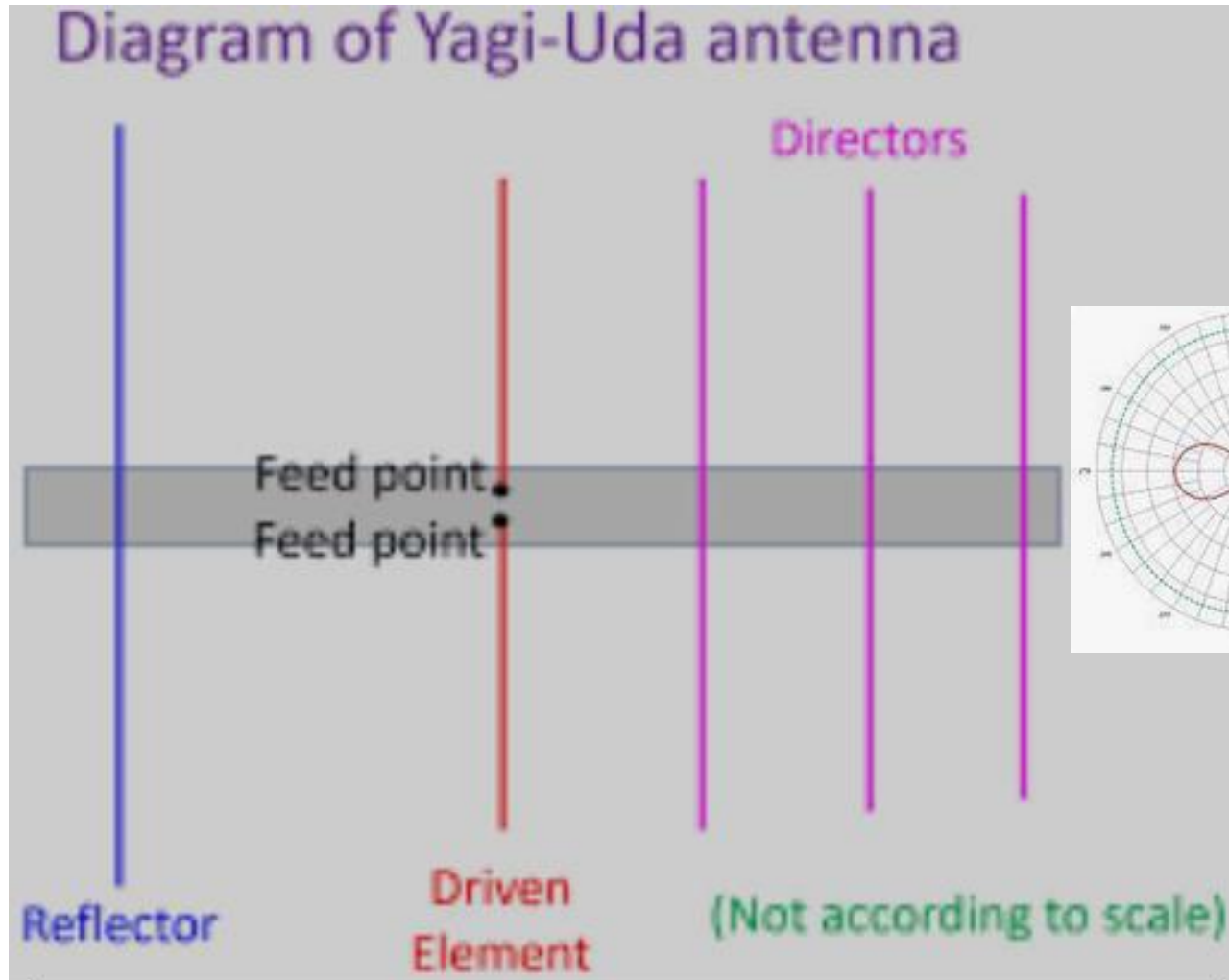

Hex Beam Theory

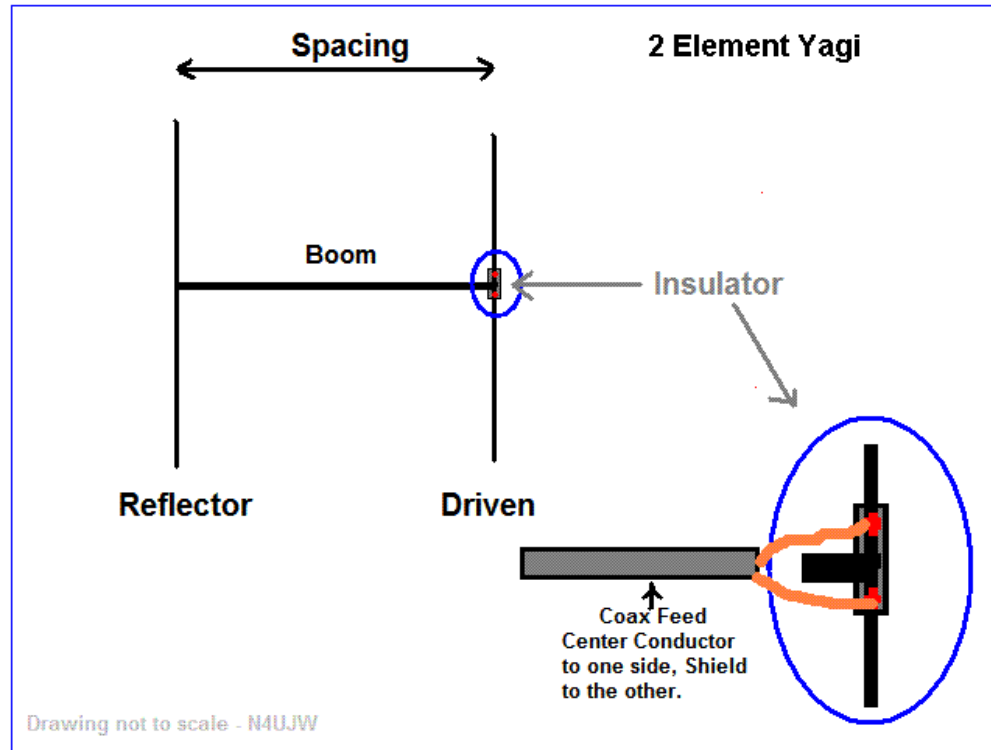

Gain is about 5dBd.

Reflector is 5% longer than the Driven Element.

Spacing can vary from 0.15-Wave to 0.25-Wavelengths, with little change in the array gain.

Hex Beam: Single Yagi Element

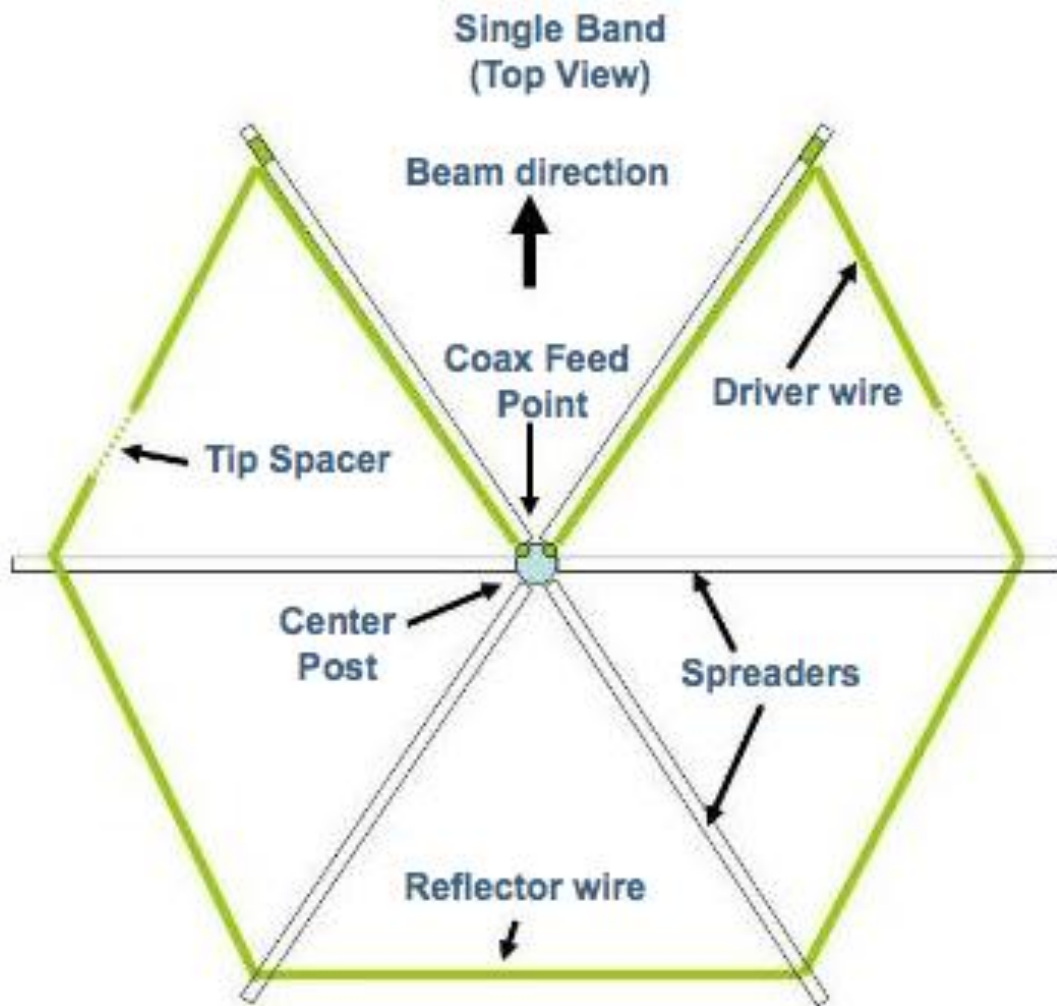

Hex Beam: Multi-Band

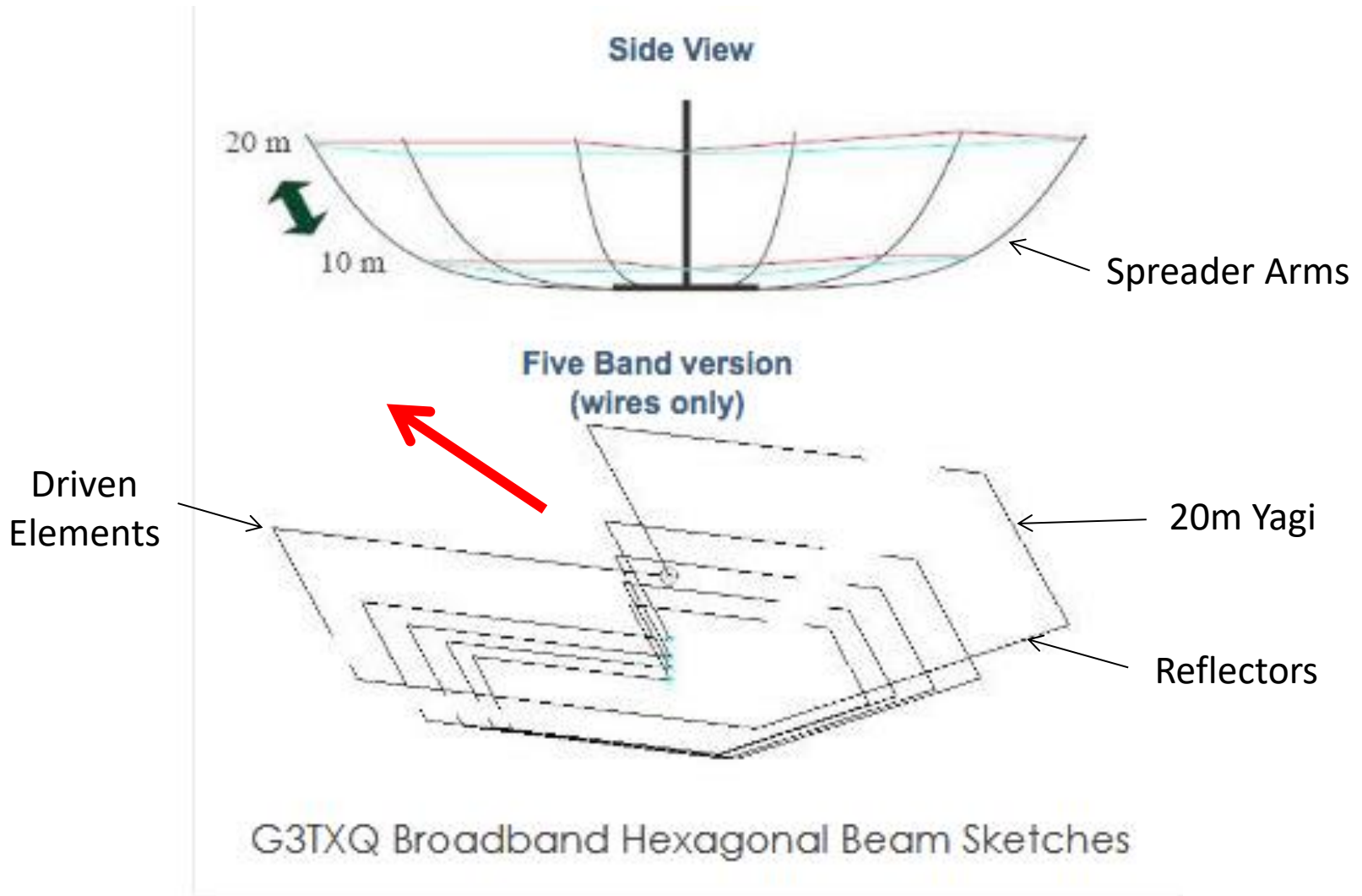

EZNEC Geometry

G3TXQ HEX BEAM
Height – 55 ft.
Wire - #16 AWG Cu
Transmission Line – 100 ft. of
LMR-400

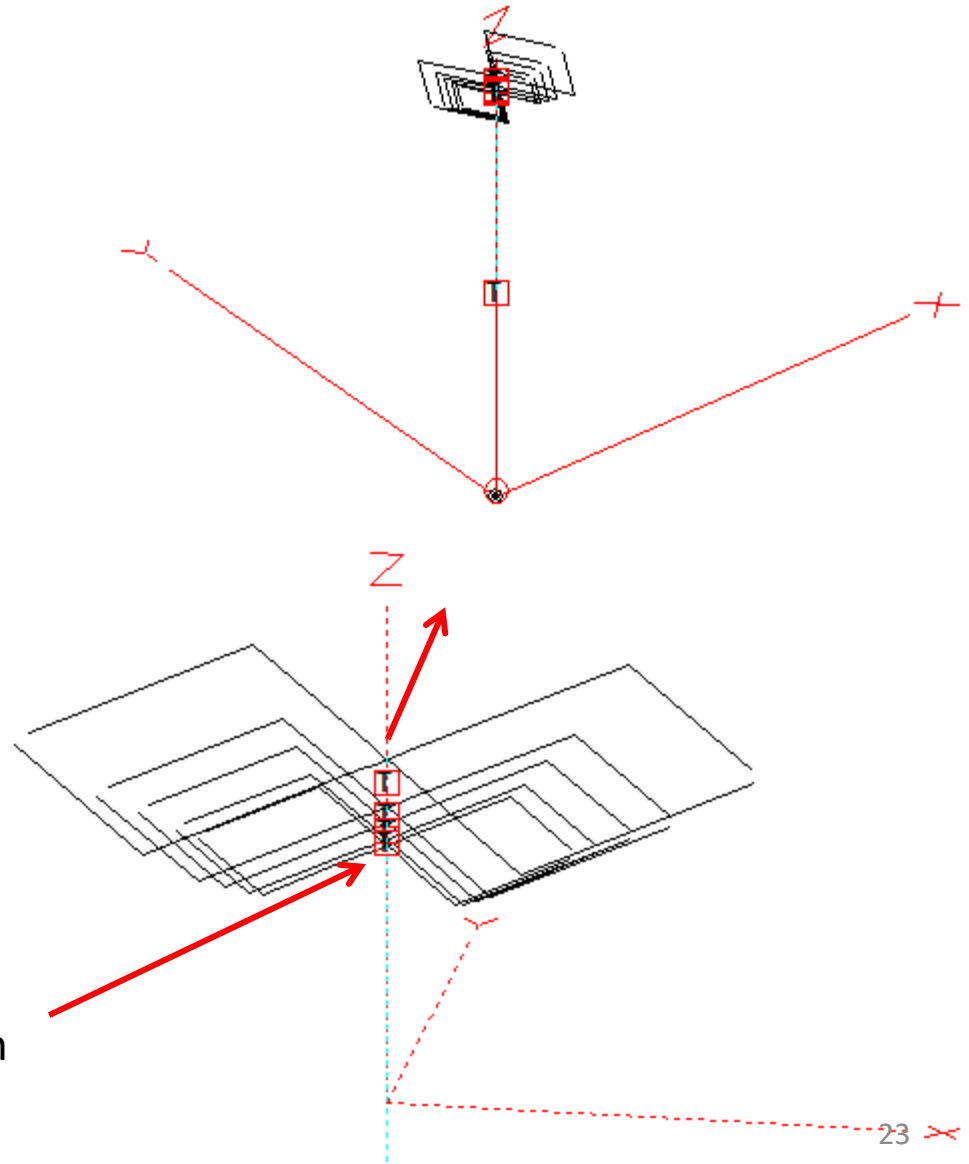

Separate Hex Yagi's are
Connected in Parallel
Using short transmission
Lines

EZNEC Pro Setup

EZNEC Pro/4 v. 6.0

File Edit Options Outputs Setups View Utilities Help

Open
Save As
Ant Notes

Currents
Src Dat
Load Dat
FF Tab
NF Tab
SWR
View Ant

NEC-2
FF Plot

> **hex beam all freq**

File hex beam all freq 55 ft...EZ

> **Frequency** 14.2 MHz

Wavelength 831.187 in

> **Wires** 150 Wires, 320 segments

> **Sources** 1 Source

> **Loads** 0 Loads

> **Trans Lines** 4 Transmission Lines

> **Transformers** 0 Transformers

> **L Networks** 0 L Networks

> **Y Param Networks** 0 Y Param Networks

> **Ground Type** Real/High Accuracy

> **Ground Descrip** 1 Medium (0.0303, 20)

> **Wire Loss** Copper

> **Units** Inches

> **Plot Type** 3D

> **Step Size** 5 Deg.

> **Ref Level** 0 dBi

> **Alt SWR Z0** 50 ohms

> **Desc Options**

> **Gnd Wave Dist** OFF

Average Gain = 0.777 = -1.10 dB *Model contains loss*

Sources

Source Edit Other

Sources

No.	Specified Pos.		Actual Pos.		Amplitude	Phase	Type
	Wire #	% From E1	% From E1	Seg	(V, A)	(deg.)	
▶ 1	151	50	50	2	1	0	V
*							

Media

Medium Edit Other

Ground Description

No.	Cond.	Diel. Const.	Height	R Coord.
	(S/m)		(in)	(in)
▶ 1	0.0303	20	0	0
*				

SWR

10 – 30 MHz

Low SWR Frequencies:

14.2 MHz

18.4 MHz

21.6 MHz

25.4 MHz

29.8 MHz

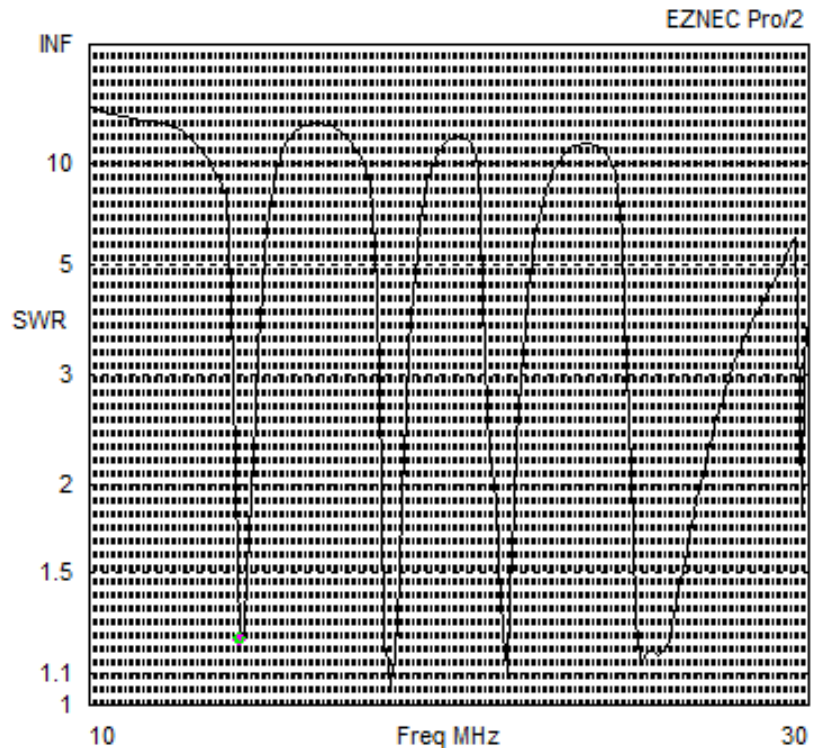

Freq	14.2 MHz	Source #	1
SWR	1.22	Z0	50 ohms
Z	60.52 at -2.25 deg. = 60.48 - j 2.376 ohms		
Refl Coeff	0.09721 at -11.55 deg. = 0.09524 - j 0.01946		
Ret Loss	20.2 dB		

Azimuth & Elevation – 14.2 MHz

EZNEC Pro/2

Total Field

EZNEC Pro/2

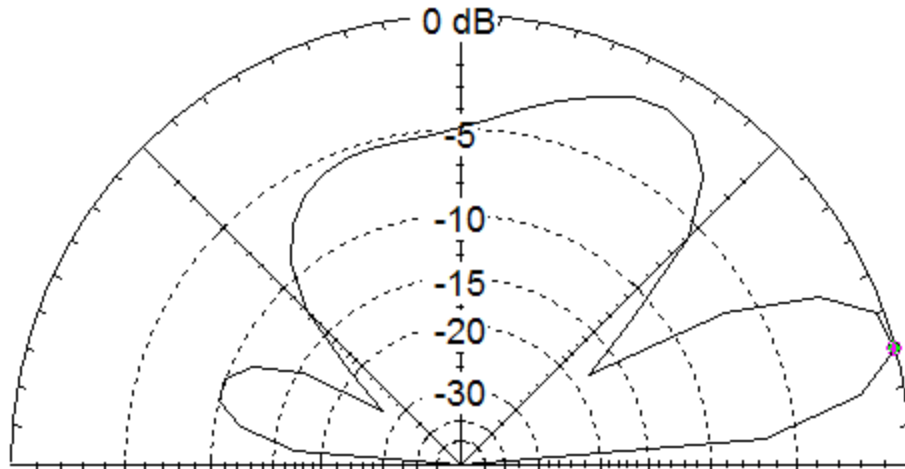

14.2 MHz

Elevation Plot
 Azimuth Angle 90.0 deg.
 Outer Ring 8.74 dBi

3D Max Gain 8.74 dBi
 Slice Max Gain 8.74 dBi @ Elev Angle = 15.0 deg.
 Beamwidth 17.2 deg.; -3dB @ 8.7, 25.9 deg.
 Sidelobe Gain 7.19 dBi @ Elev Angle = 60.0 deg.
 Front/Sidelobe 1.55 dB

Cursor Elev 15.0 deg.
 Gain 8.74 dBi
 0.0 dBmax
 0.0 dBmax3D

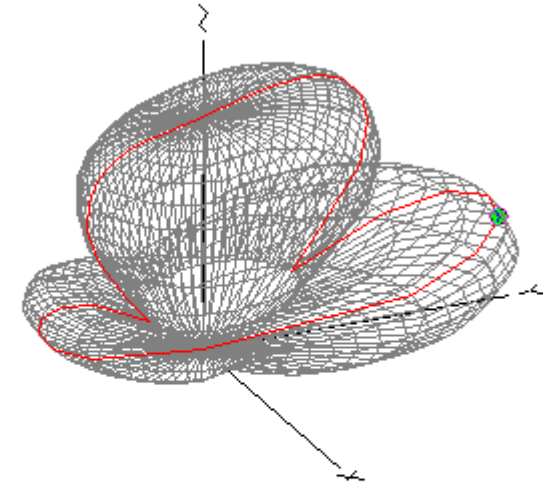

Total Field

EZNEC Pro/2

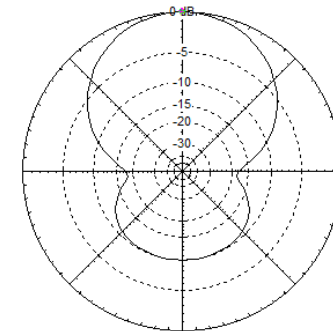

14.2 MHz

Azimuth Plot
 Elevation Angle 15.0 deg.
 Outer Ring 8.74 dBi

3D Max Gain 8.74 dBi
 Slice Max Gain 8.74 dBi @ Az Angle = 90.0 deg.
 Front/Back 10.05 dB
 Beamwidth 83.6 deg.; -3dB @ 48.2, 131.8 deg.
 Sidelobe Gain -1.31 dBi @ Az Angle = 270.0 deg.
 Front/Sidelobe 10.05 dB

Cursor Az 90.0 deg.
 Gain 8.74 dBi
 0.0 dBmax
 0.0 dBmax3D

Azimuth & Elevation – 18.110 MHz

Total Field

EZNEC Pro/4

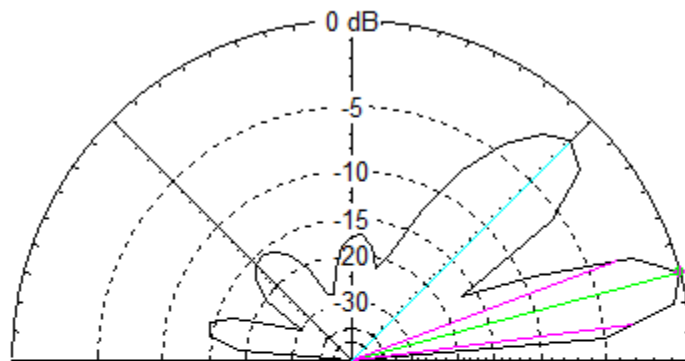

18.11 MHz

Elevation Plot		Cursor Elev	15.0 deg.
Azimuth Angle	90.0 deg.	Gain	10.62 dBi
Outer Ring	10.62 dBi		0.0 dBmax
			0.0 dBmax3D
3D Max Gain	10.62 dBi		
Slice Max Gain	10.62 dBi @ Elev Angle = 15.0 deg.		
Beamwidth	13.3 deg.; -3dB @ 7.2, 20.5 deg.		
Sidelobe Gain	9.06 dBi @ Elev Angle = 45.0 deg.		
Front/Sidelobe	1.56 dB		

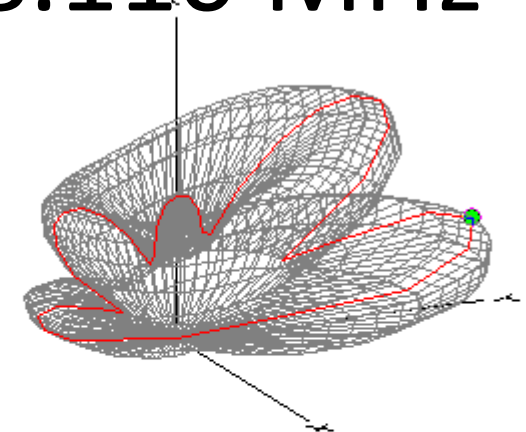

Total Field

EZNEC Pro/4

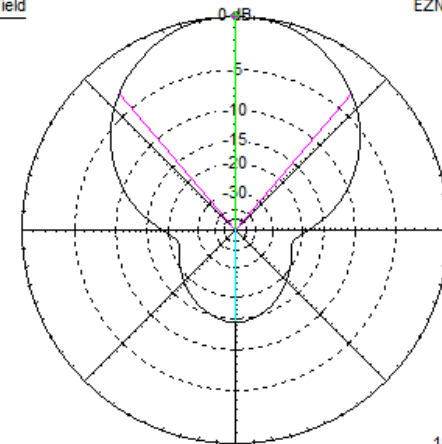

18.11 MHz

Azimuth Plot		Cursor Az	90.0 deg.
Elevation Angle	15.0 deg.	Gain	10.62 dBi
Outer Ring	10.62 dBi		0.0 dBmax
			0.0 dBmax3D
3D Max Gain	10.62 dBi		
Slice Max Gain	10.62 dBi @ Az Angle = 90.0 deg.		
Front/Back	14.42 dB		
Beamwidth	81.0 deg.; -3dB @ 49.5, 130.5 deg.		
Sidelobe Gain	-3.8 dBi @ Az Angle = 270.0 deg.		
Front/Sidelobe	14.42 dB		

Azimuth & Elevation – 21.3 MHz

Total Field

EZNEC Pro/4

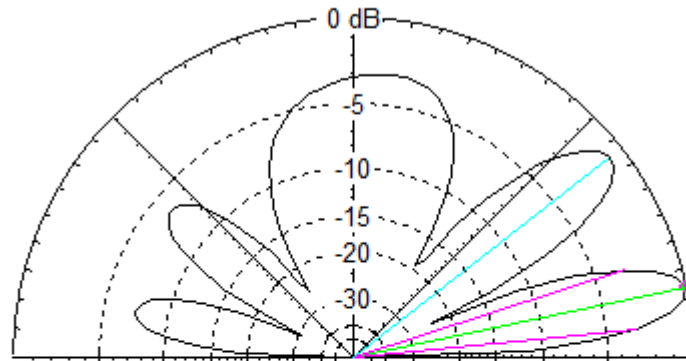

21.3 MHz

Elevation Plot		Cursor Elev	12.0 deg.
Azimuth Angle	90.0 deg.	Gain	9.51 dBi
Outer Ring	9.51 dBi		0.0 dBmax
			0.0 dBmax3D
3D Max Gain	9.51 dBi		
Slice Max Gain	9.51 dBi @ Elev Angle = 12.0 deg.		
Beamwidth	12.0 deg.; -3dB @ 5.8, 17.8 deg.		
Sidelobe Gain	8.74 dBi @ Elev Angle = 38.0 deg.		
Front/Sidelobe	0.77 dB		

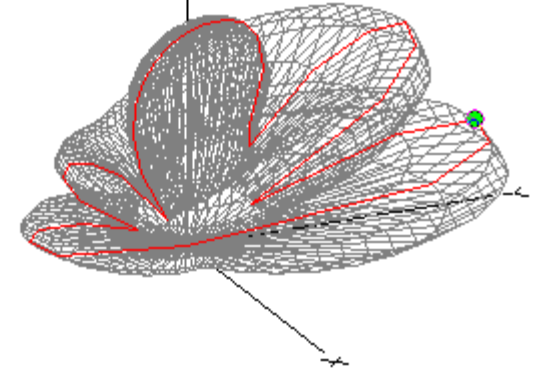

Total Field

EZNEC Pro/4

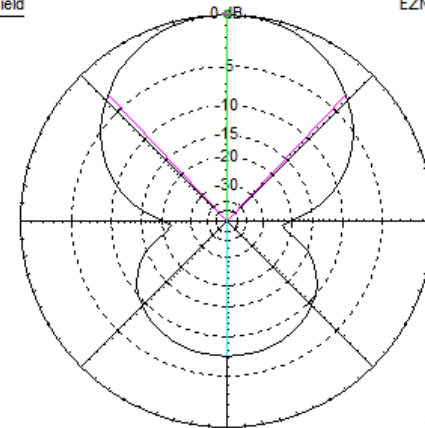

21.3 MHz

Azimuth Plot		Cursor Az	90.0 deg.
Elevation Angle	10.0 deg.	Gain	9.3 dBi
Outer Ring	9.3 dBi		0.0 dBmax
			0.0 dBmax3D
3D Max Gain	9.3 dBi		
Slice Max Gain	9.3 dBi @ Az Angle = 90.0 deg.		
Front/Back	7.31 dB		
Beamwidth	87.0 deg.; -3dB @ 46.5, 133.5 deg.		
Sidelobe Gain	1.99 dBi @ Az Angle = 270.0 deg.		
Front/Sidelobe	7.31 dB		

Azimuth & Elevation – 24.93 MHz

EZNEC Pro/4

Total Field

EZNEC Pro/4

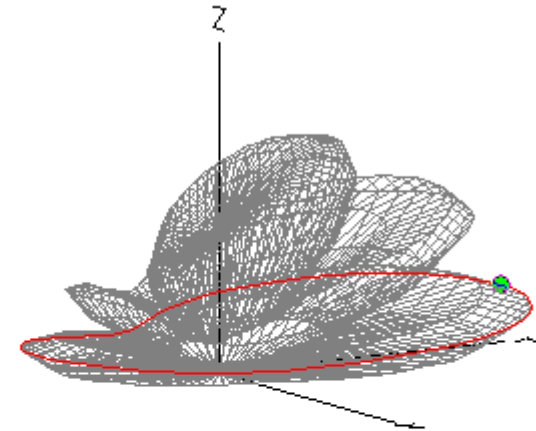
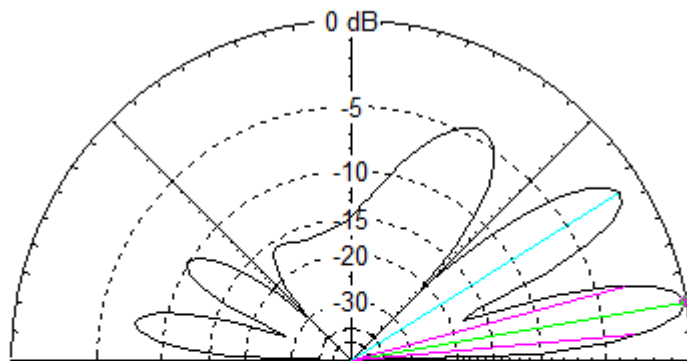

Total Field

EZNEC Pro/4

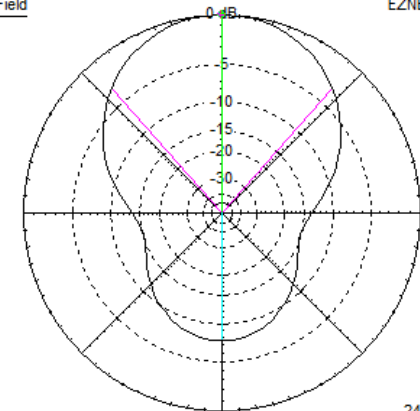

24.93 MHz

Elevation Plot
Azimuth Angle 90.0 deg.
Outer Ring 11.62 dBi

Cursor Elev 10.0 deg.
Gain 11.62 dBi
0.0 dBmax
0.0 dBmax3D

3D Max Gain 11.62 dBi
Slice Max Gain 11.62 dBi @ Elev Angle = 10.0 deg.
Beamwidth 10.1 deg.; -3dB @ 5.1, 15.2 deg.
Sidelobe Gain 10.38 dBi @ Elev Angle = 32.0 deg.
Front/Sidelobe 1.24 dB

24.93 MHz

Azimuth Plot
Elevation Angle 10.0 deg.
Outer Ring 11.62 dBi

Cursor Az 90.0 deg.
Gain 11.62 dBi
0.0 dBmax
0.0 dBmax3D

3D Max Gain 11.62 dBi
Slice Max Gain 11.62 dBi @ Az Angle = 90.0 deg.
Front/Back 7.55 dB
Beamwidth 83.0 deg.; -3dB @ 48.5, 131.5 deg.
Sidelobe Gain 4.07 dBi @ Az Angle = 270.0 deg.
Front/Sidelobe 7.55 dB

Azimuth & Elevation – 28.3 MHz

EZNEC Pro/4

Total Field

EZNEC Pro/4

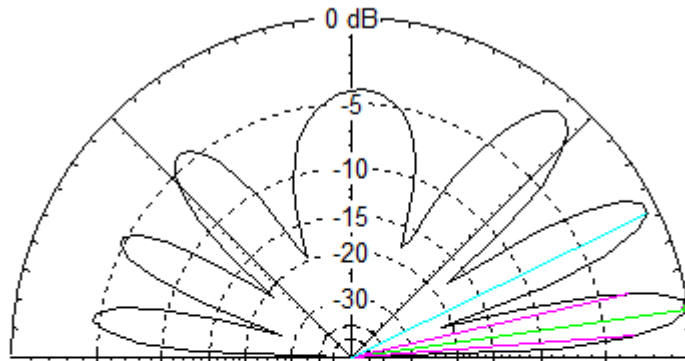

28.93 MHz

Elevation Plot		Cursor Elev	8.0 deg.
Azimuth Angle	90.0 deg.	Gain	9.63 dBi
Outer Ring	9.63 dBi		0.0 dBmax
			0.0 dBmax3D
3D Max Gain	9.63 dBi		
Slice Max Gain	9.63 dBi @ Elev Angle = 8.0 deg.		
Beamwidth	8.6 deg.; -3dB @ 4.3, 12.9 deg.		
Sidelobe Gain	9.15 dBi @ Elev Angle = 26.0 deg.		
Front/Sidelobe	0.48 dB		

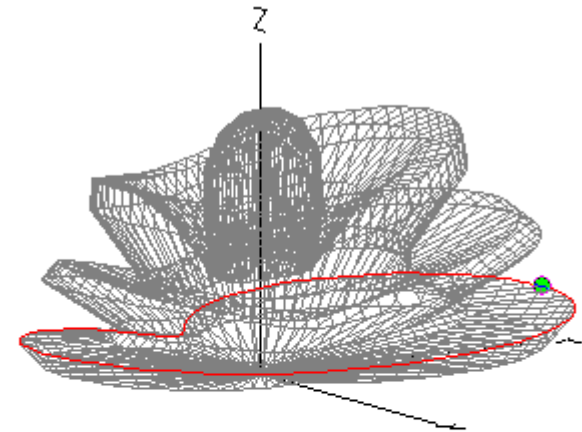

Total Field

EZNEC Pro/4

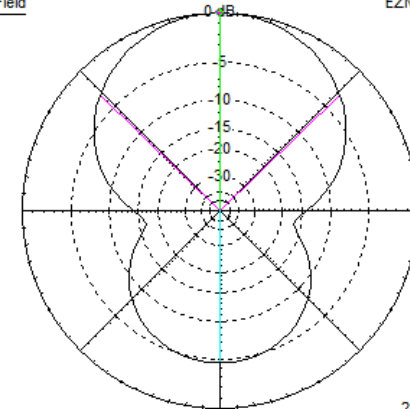

28.93 MHz

Azimuth Plot		Cursor Az	90.0 deg.
Elevation Angle	10.0 deg.	Gain	9.41 dBi
Outer Ring	9.41 dBi		0.0 dBmax
			0.0 dBmax3D
3D Max Gain	9.41 dBi		
Slice Max Gain	9.41 dBi @ Az Angle = 90.0 deg.		
Front/Back	4.54 dB		
Beamwidth	92.4 deg.; -3dB @ 43.8, 136.2 deg.		
Sidelobe Gain	4.87 dBi @ Az Angle = 270.0 deg.		
Front/Sidelobe	4.54 dB		

Single Band Yagi-Uda Antenna

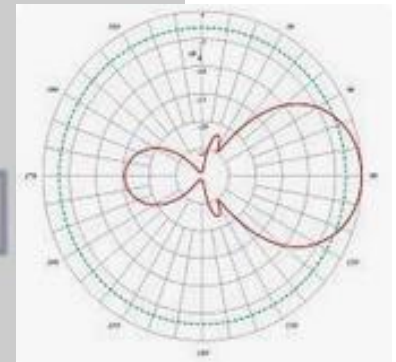
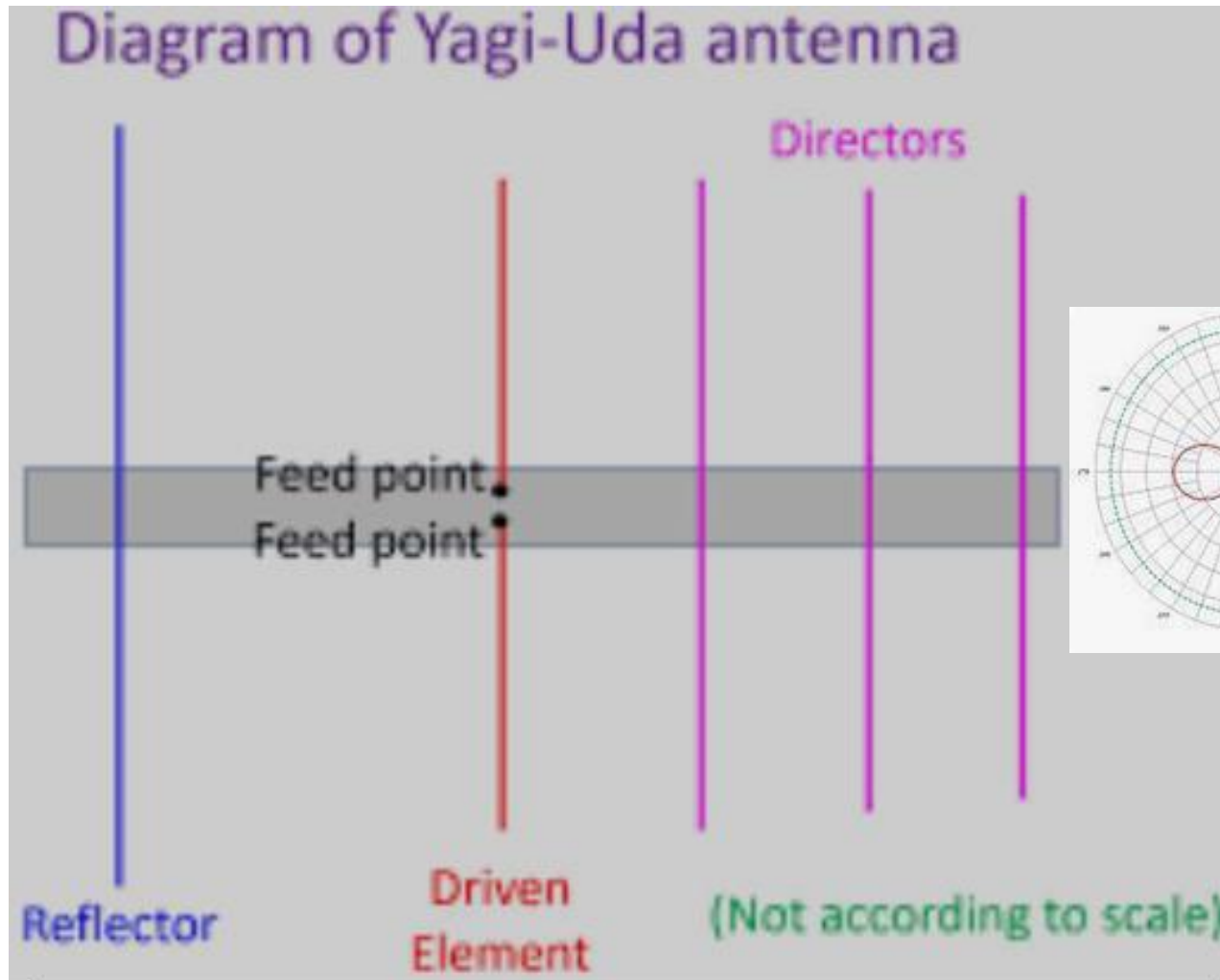

Homebrew 3 element 20m Yagi

From July 2001 QST © ARRL

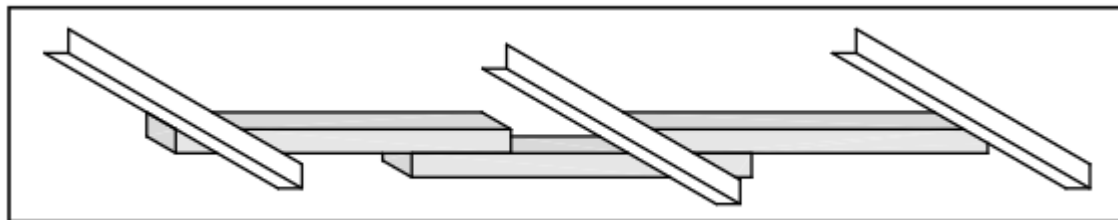
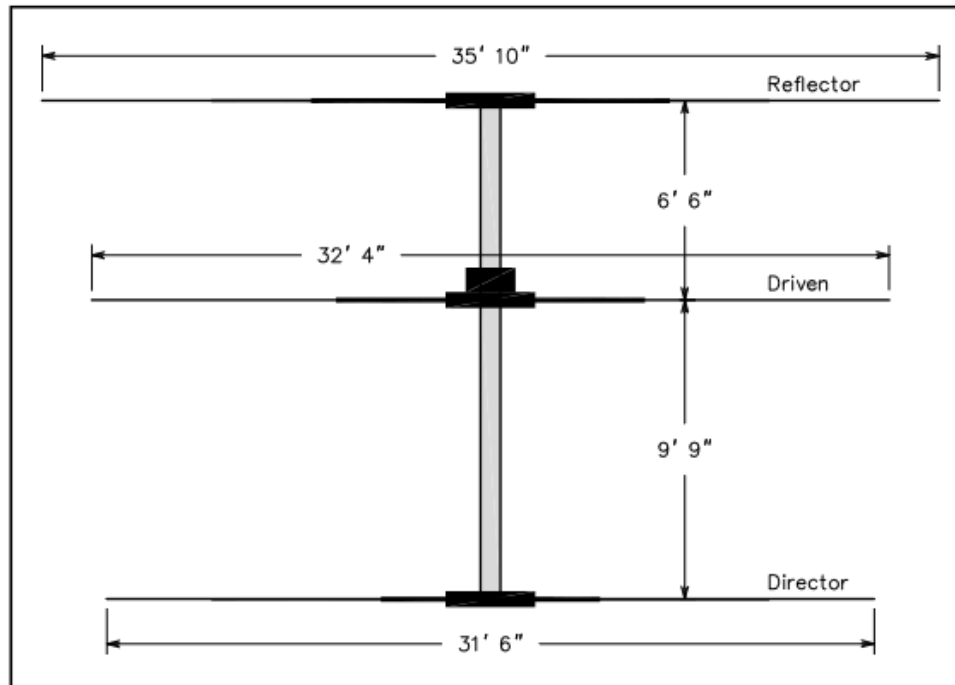

Figure 2—The boom and element brackets.

Commercial Multi-Band Yagi



\$2,350.97

[DX Engineering Skyhawk Tri-Band Yagi Antennas](#)

Antenna, Yagi, Skyhawk, Tri-Band 20, 15, 10 meters, 20m, 15m, 10m, 10 Elements, 2.5 kW, **24 ft. Boom,**

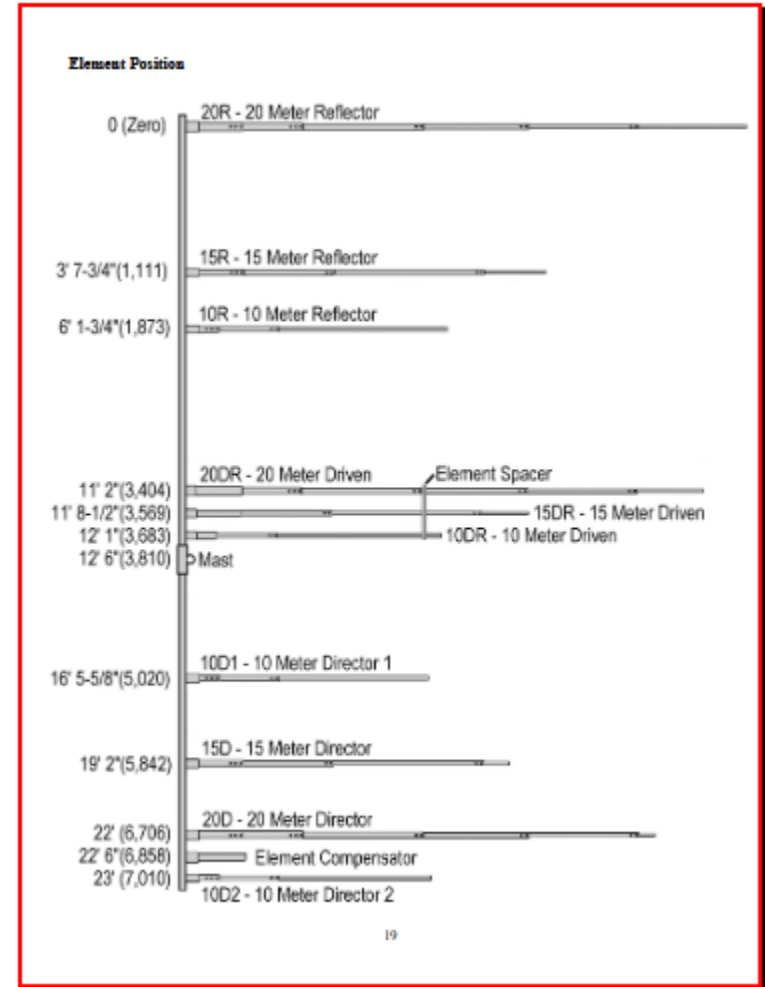

Homebrew Multi-Band Wire Yagi

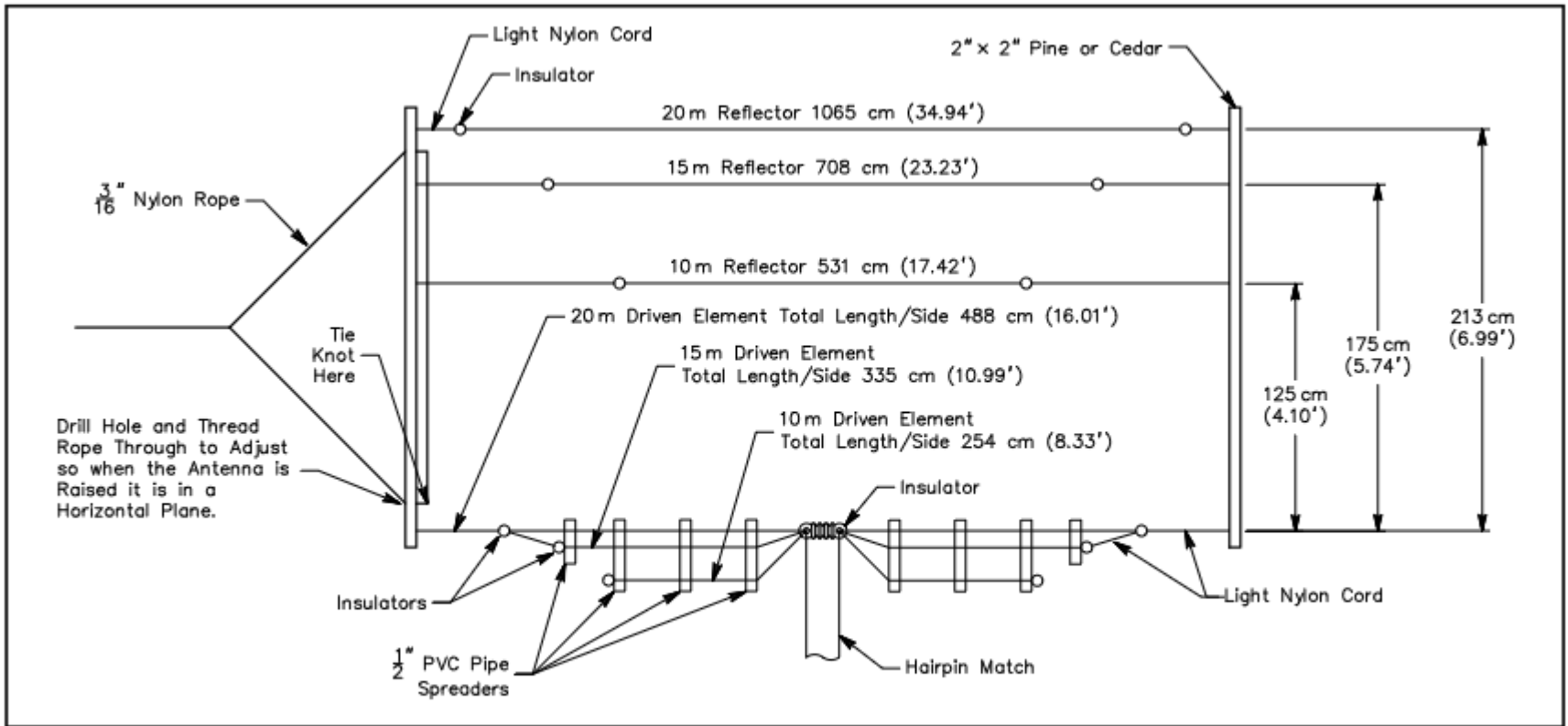
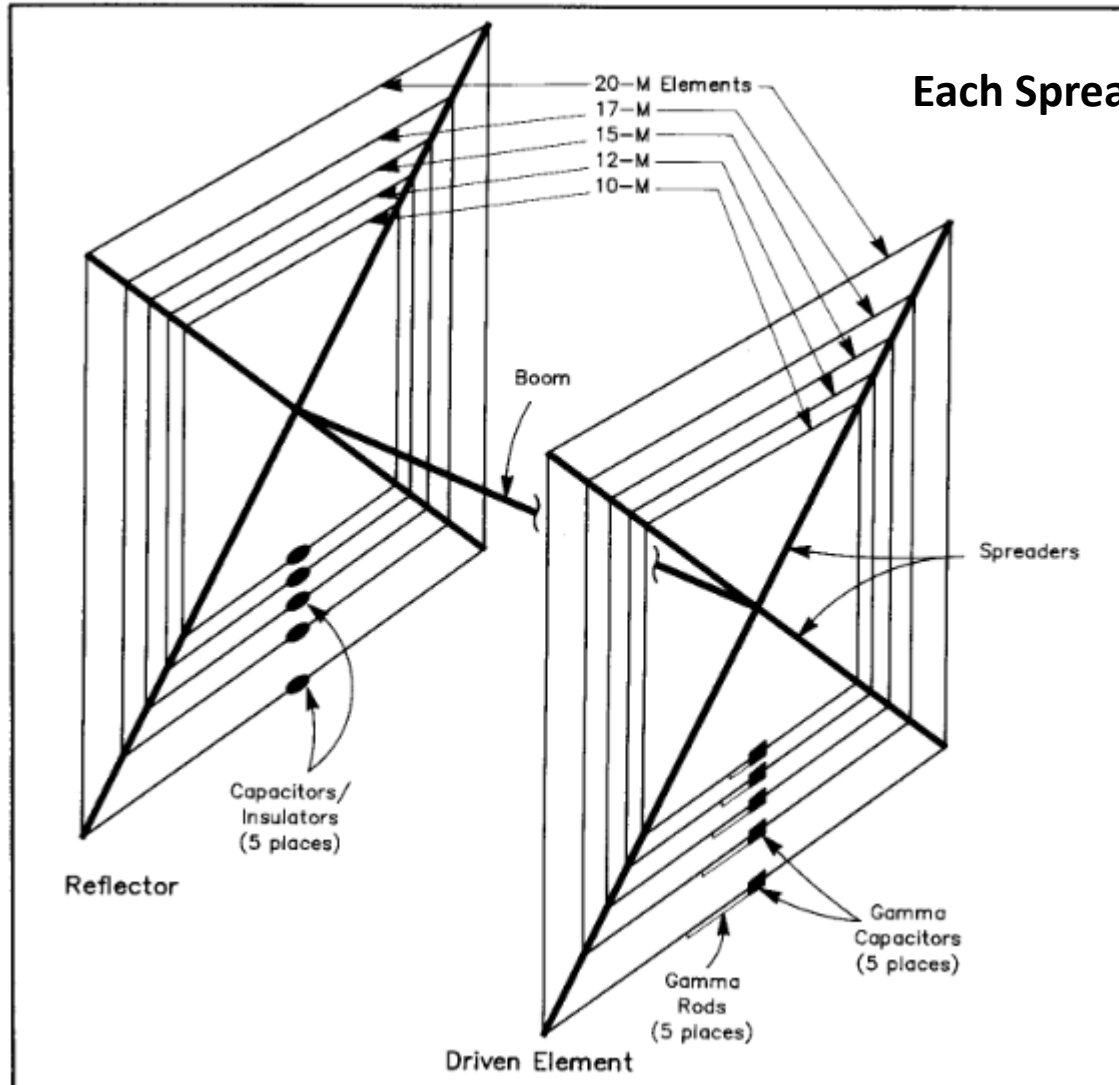

Figure 1—Dimensions for VE7CA's 2-element wire triband Yagi.

Homebrew Cubical Quad 5-band Yagi

April 1992 QST



Continuous Frequency Coverage Yagi STEPPIR

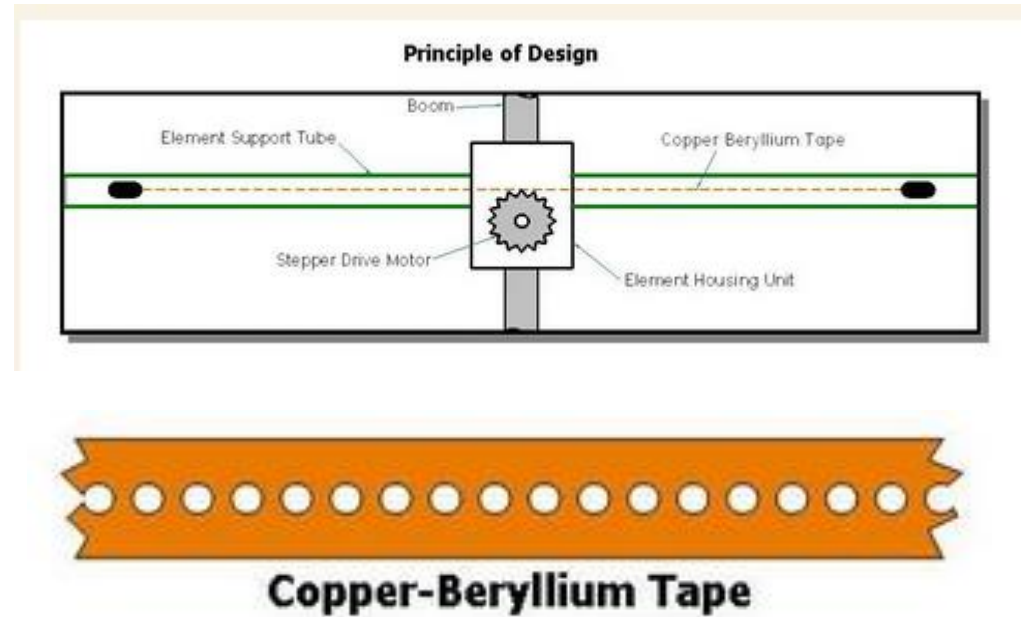

Continuous Frequency Coverage Yagi SteppIR

DB36 Yagi Antenna, 80m-6m Package

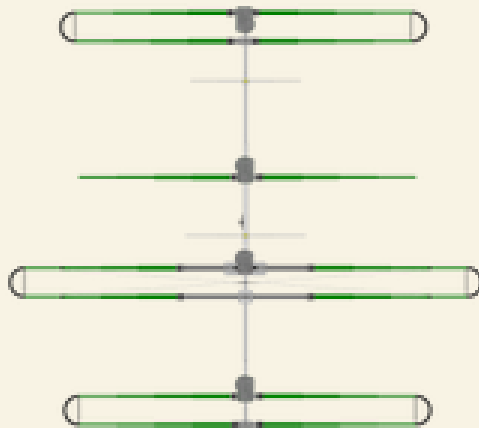

- DB36 Yagi, 80m-6m (w/ SDA 100)
- DB36 Yagi, 80m-6m (w/ OptimizIR 2.0)

Package includes:

- Connector junction box
- Element truss kit
- Single Boom Truss (Boom Double Truss Upgrade Available)
- 6m Passive element kit
- 80m dipole kit
- DB25 Cable splice
- Pre-Wired Control Cable
- Reinforced DB Mounting Plate
- High Performance Balun
- 36V, 4.14A Power Supply

\$9,603.77 – \$10,153.77

Tennadyne Log Periodic Antennas



Model	Coverage	Gain (dbd/dbi)	Boom Length	Elements	Longest	Turn Radius	Wind Load	Weight	Price
T6	13 – 30 MHz	5.10/7.24	12 FT	6	38 FT	20 FT	6.2	47#	\$1,095
T7	18 – 32 MHz	6.2/8.3	18 FT	7	29 FT	16.5 FT	6.8	53#	\$1,290
T8	13 – 32 MHz	5.80/8.34	18 FT	8	38 FT	20.9 FT	8	68#	\$1,480
T10	13 – 33 MHz	6.10/8.24	24 FT	10	38 FT	22 FT	10.1	78#	\$1,825
T11	13 – 55 MHz	5.80/7.94	24 FT	11	38 FT	21.5 FT	8.5	73#	\$1,965
T12	13 – 33 MHz	6.50/8.64	30 FT	12	38 FT	24.6 FT	11.7	97#	\$2,435

Tower Wind Loading

- Towers designed for mounting horizontal antennas will have a maximum stated wind load given in Sq. Ft. of largest recommended antenna at a given wind speed.
- Each Yagi antenna will list its Sq. Ft. area.
- The tower and antenna selections should be matched so that the antenna tower is not overloaded by too large an antenna. Note that the height of the antenna above the top of the tower must be taken into consideration since this additional height increases the rotational moment loading.

Rohn 25G – 80 ft. Guyed



Two Point Anchor of Rohn 25G

- Rohn 25G is man-climbable to 50 ft. when base is set in concrete and a strong house bracket is used at a height of 15-20 ft.

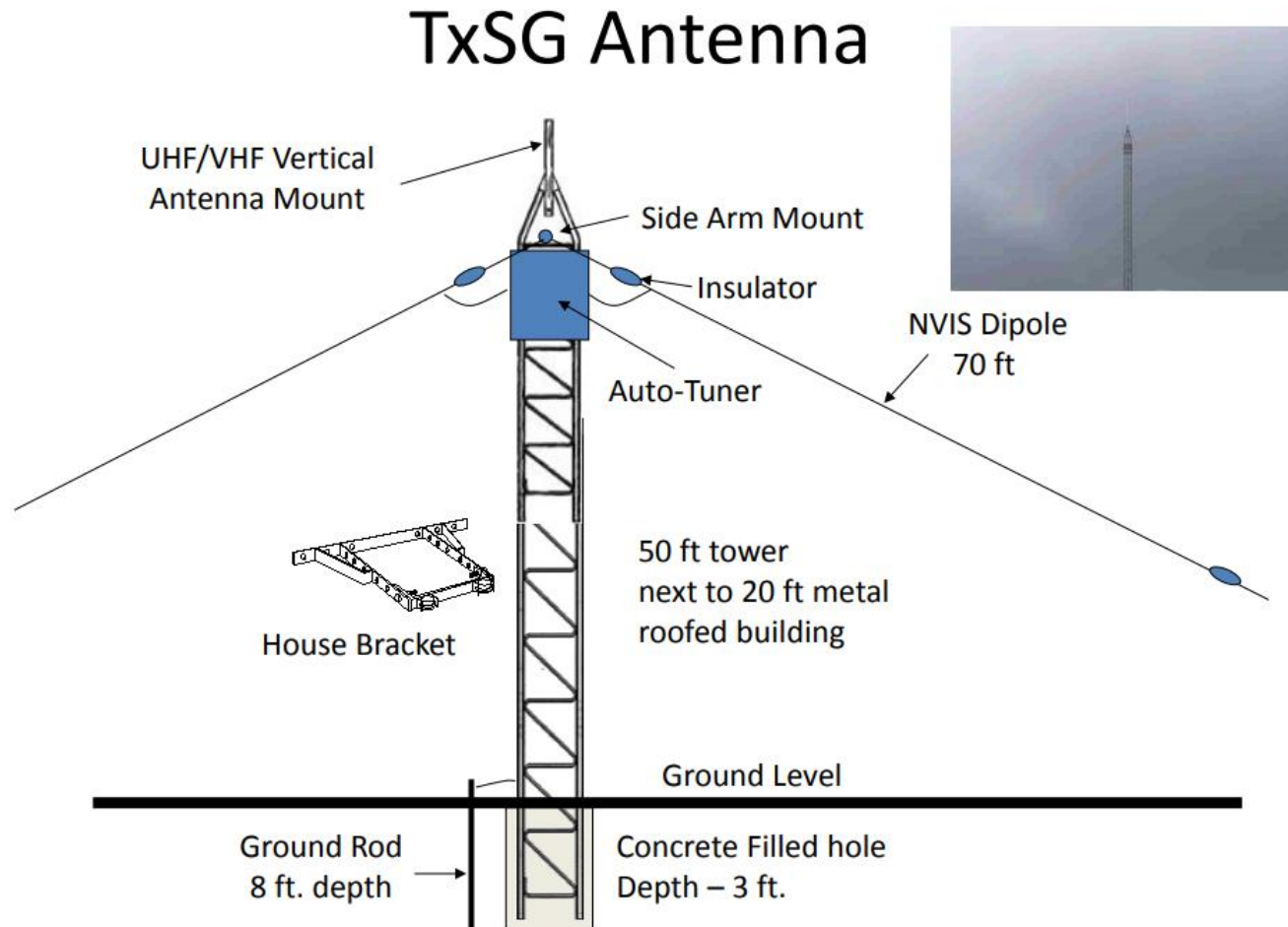

Two Point Anchor with Glen Martin Hazer



Two Point Anchor with Razor

<http://www.rtinnovations.net/>

Rohn 25 G - \$900.



Hazer System

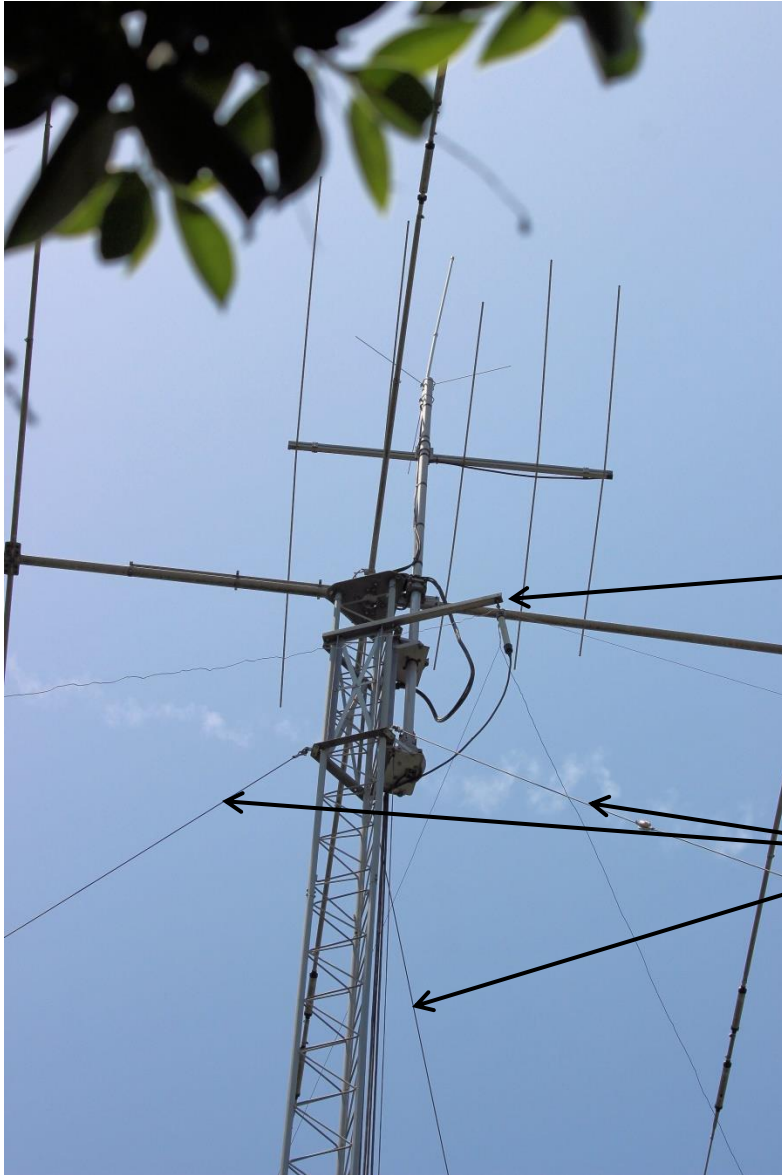

Advantages:

- Can lower Antenna system to roof top for maintenance.
- Only have to climb tower to top once to install pulley.
- Does include fail-safe lock

Dipole Hanger
Dipole Balun

Guy Cables

60 ft. Hazer Antenna System

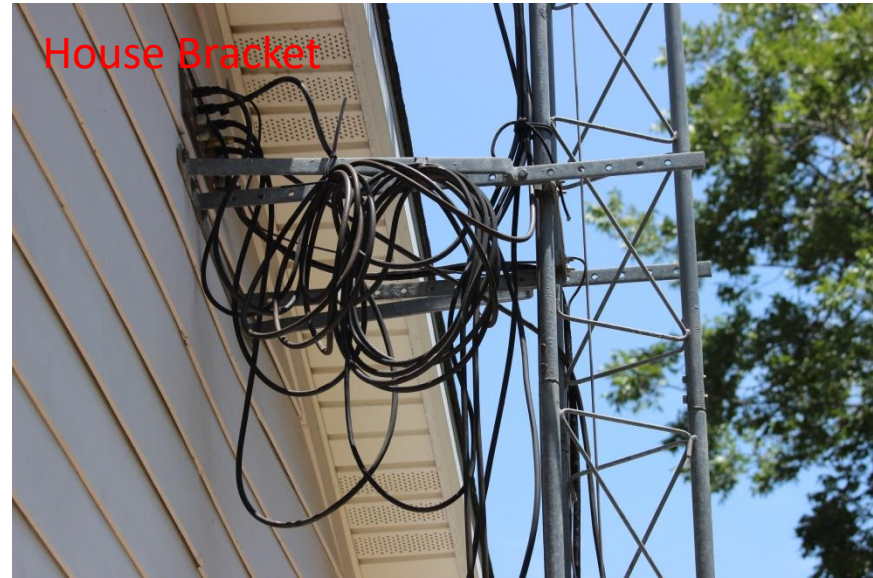
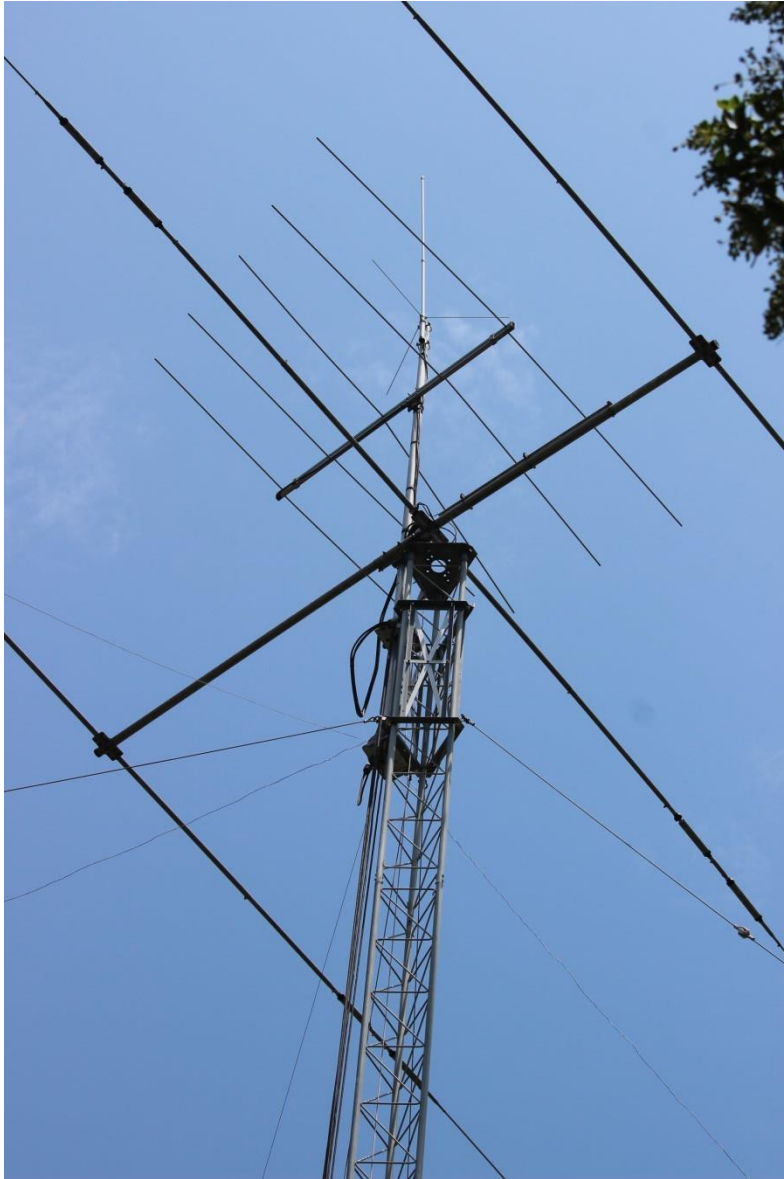

Hazer Winch

HF Long-Range Antenna Conclusions

- Two factors affect your ability to successfully conduct long-range HF contacts:
 - Achieving a low TOA elevation angle.
 - Operating at the MUF for the reflection point.
- Antenna towers must be installed as per manufacturer's recommendations.
- Wind loading must be considered with selecting tower height and type of tower and antenna.

Outline

Red is Next Month's Subject

- HF Propagation Modes
- Long Distance, HF Sky-Wave hardware and modes
 - Antenna Requirements
- Antenna Types
 - Verticals
 - High Dipoles
 - Yagi's
- HF Skywave Propagation theory and Prediction
 - Theory
 - Prediction Program – VOACAP
 - Beacons

Questions?

Lewis Thompson – W5IFQ

Personal Cell – 512-587-9944

Home E-mail: w5ifq@att.net

HF Propagation Determination

- A simplified behavior of HF sky-wave propagation using world wide Ionosonde data will allow a basic understanding of the phenomena.
- Propagation computer prediction programs will provide a more realistic behavior that included more complex propagation paths.
- Finally, actual reception of world-wide propagation will be discussed using the NCDXF Beacon system.

Simplified HF Sky Wave Propagation

- A successful Sky-wave propagation path requires that the Maximum Useable Frequency (MUF) at the **reflection** location be equal to or exceed the operating frequency.
- The required MUF is dependent on Cosine of the TOA.
- For simple F2 layer to earth bounces, this requirement must be met for each succeeding reflection for a multi-hop circuit.

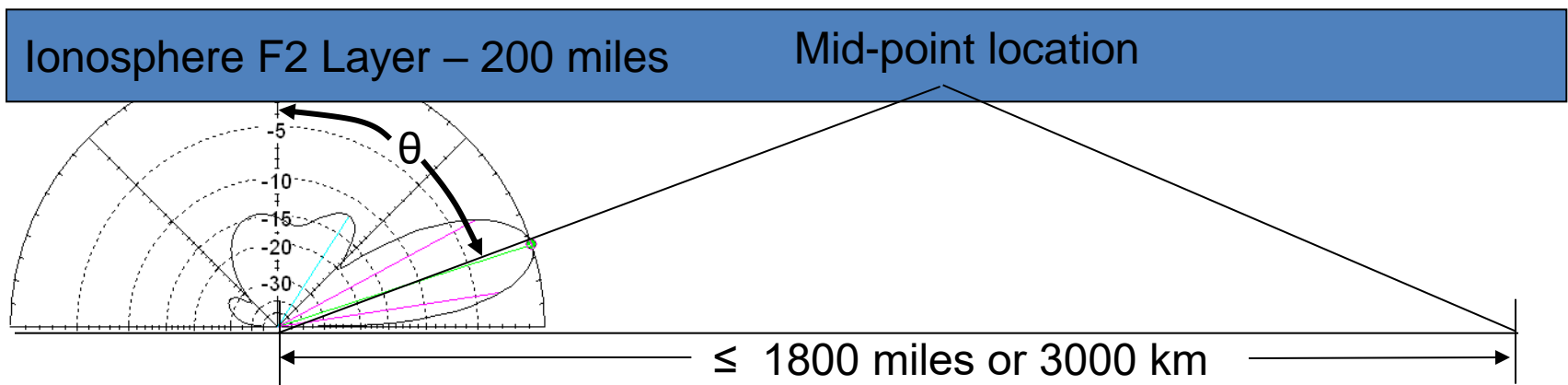

Maximum Useable Frequency (MUF)

- MUF (Maximum Useable Frequency) is $CF/\cos\theta$, where θ is the angle from the take-off beam to vertical.

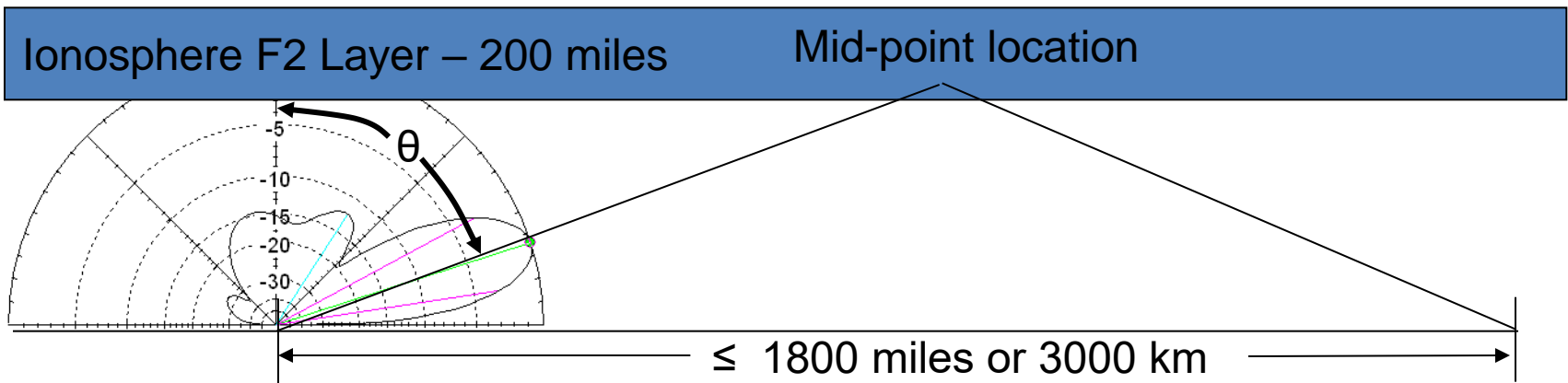

MUF World Wide Distribution

- The Critical Frequency (CF) and therefore the MUF at the reflection point is dependent on the **local level of UV radiation** from the sun.
- The UV radiation at this location is dependent on the following:
 - Time day
 - Time of the Year
 - Time of the 11 year sun spot cycle
- The CF may also be affected by Solar and Geomagnetic storm events.

MUF Distribution – 28 FEB 2025

(<https://prop.kc2g.com/>)

mufd 2025-02-28 15:15 eSFI: 146.7, eSSN: 112.4

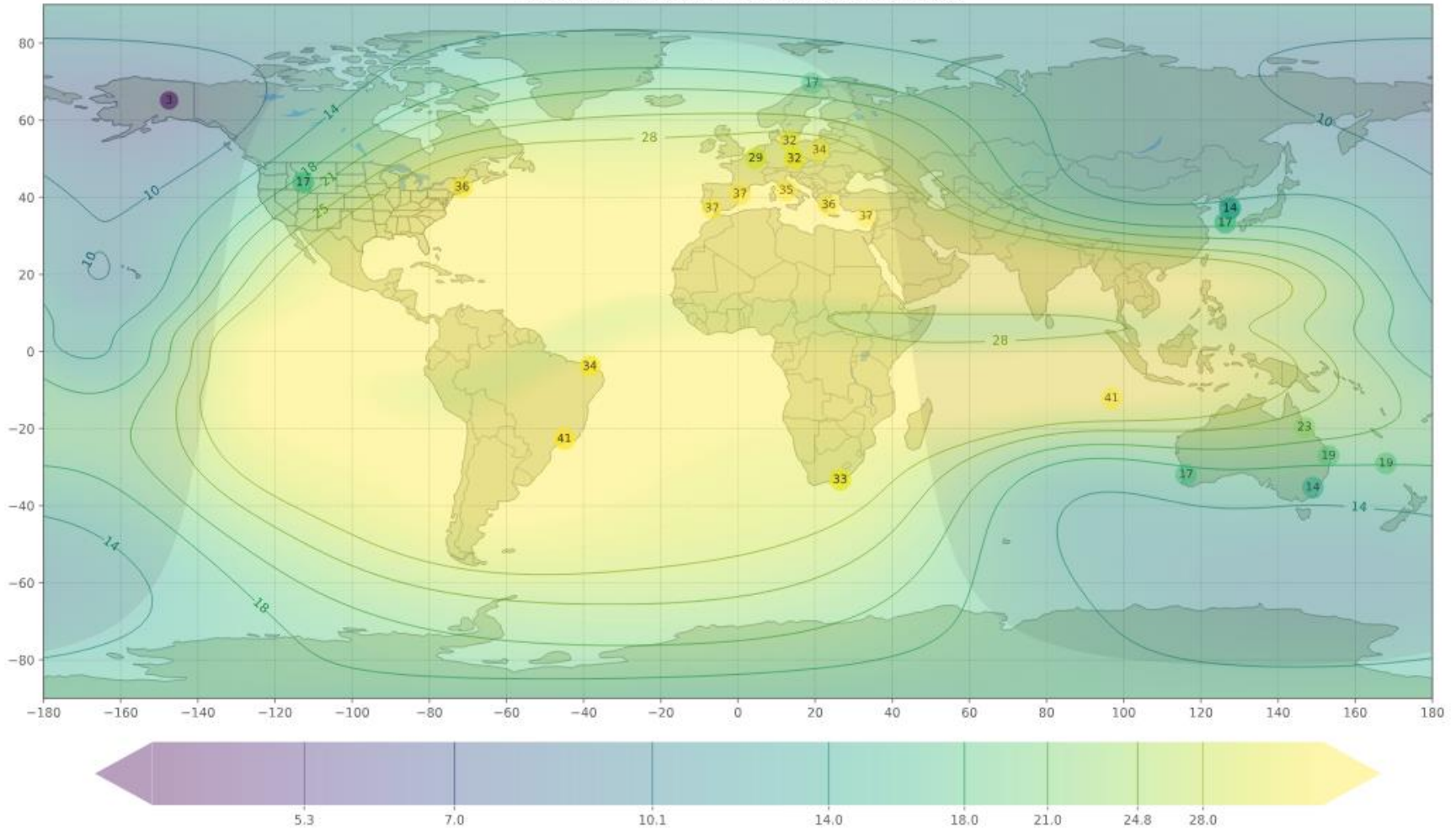

MUF World Wide Distribution

- As expected, the MUF and CF are highest in the sun lite portion of the earth.
- I recommend the use of GAMBIT to obtain Critical Frequencies (foF2) at any location in the world. From this data, the MUF for a specific, single bounce can be calculated.

Introduction

- **NOAA is no longer supporting ionosonde data distribution.**
- The University of Massachusetts Lowell , Global Ionosphere Radio Observatory, GIRO, provides a number of useful products that can assist HF radio operators in selecting the best NVIS (Near Vertical Incident Sky wave) frequency.
- Their GAMBIT product appears to be the most useful product for long range propagation, providing foF2 (Critical Frequency) for any location. GAMBIT uses their IRTAM model to compute **foF2 every 15 minutes using real time data from their world wide ionosonde data base.**

GAMBIT Location on Army MARS Region 6 Solar Weather Page

(<https://www.region6armymars.org/resources/solarweather.php>)

- [GAMBIT](#) - Global Assimilative Model of Bottomside Ionosphere Timeline (World-Wide)
- • [Austin](#)
- [Boulder](#)
- [Eglin](#)

- [NOAA Solar Weather](#) - Solar Weather plots of Kp and X-Ray and other solar emissions.
- [Solen Solar Weather](#) - Good general solar forecast from an individual.
- [Solar Ham](#) - SolarHam provides real time solar news, as well as consolidated data from various sources.

GAMBIT for Austin Ionosonde

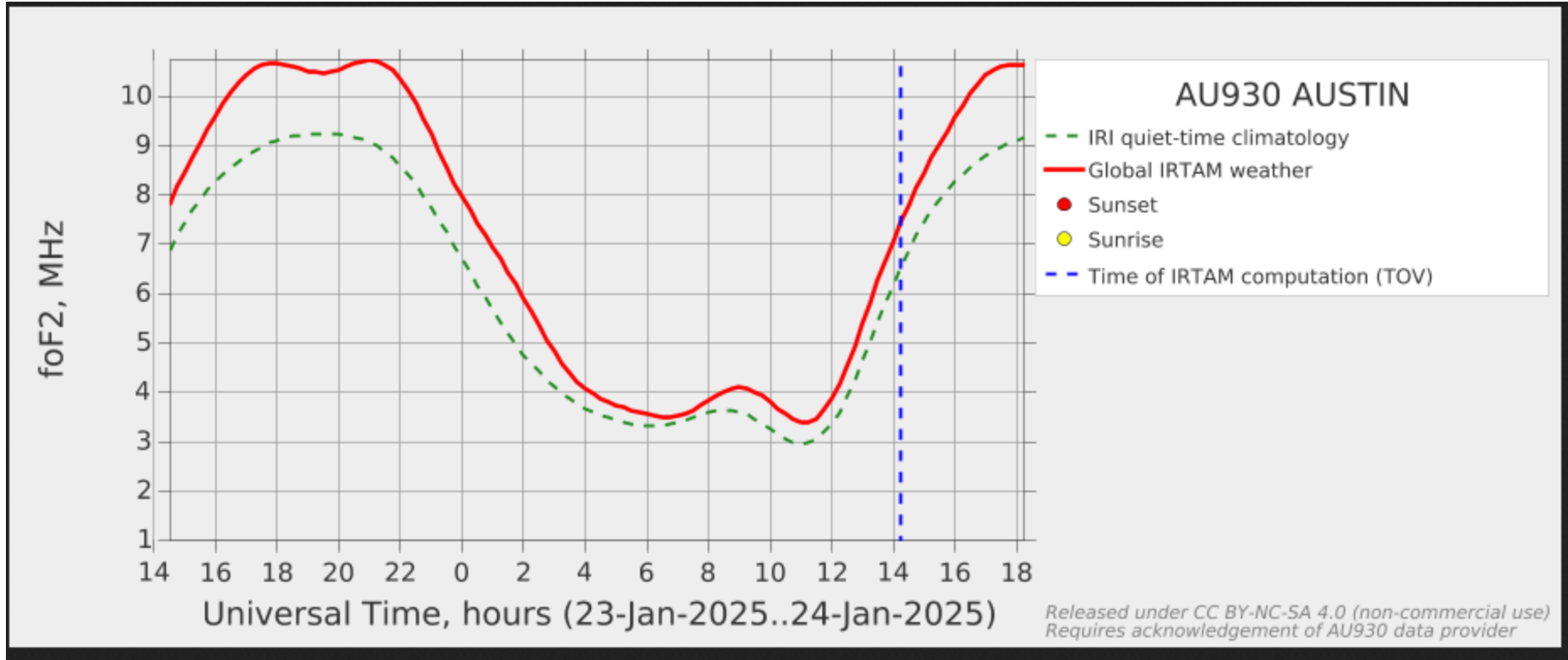

Use of GAMBIT For World-Wide foF2 Plots

- GAMBIT URL is now listed on our solar weather web page in place of DIDBase URL. You can select one of the three Ionosondes in Region 6 for foF2 Critical Frequency or use GAMBIT URL for world-wide foF2 and hmF2 calculations by either selecting another Ionosonde or by using the coordination method discussed on page 8.
 - Operation is as follows:
 - **Location** – A pull down screen allows the user to select a specific Ionosonde by name
- Characteristic fields available:**
- **foF2** - Critical Frequency, MHz
 - **NmF2** – Electron density in the F2 layer (not important)
 - **hmF2** – Height of the F2 layer, Km
 - **BO, B1** – IRI vertical profiles (not important)

check box - current date and time (you do not need to enter date and time)

Submit

If the GIRO server is available, the plot on the right will be generated. If no result wait and try again later. I would recommend copying this plot for use for the next 24 hours if no severe Ionospheric storms are forecasted. Note that date/time on the horizontal axis is in UTC and can include a change in date.

This plot can be easily copied and printed using *Snipping Tool* or similar graphical capture programs. If you distribute this data please include the source (see rules of the road).

GAMBIT Use For Any Ionosonde

GAMBIT Local Nowcast

Choose a site or type coordinates below:

Location:

Choose a characteristic:

Characteristic:

Coordinates:

Use Current Date and Time

Date

GU513 GUAM

- IRI quiet-time climatology
- Global IRTAM weather
- Sunset
- Sunrise
- Time of IRTAM computation (TOV)

Released under CC BY-NC-SA 4.0 (non-commercial use)
Requires acknowledgement of GU513 data provider

Released under CC-BY-NC-SA 4.0, see [Rules of the Road](#) for details.

If shared or published, specific data provider must be credited, see [Acknowledgement List](#).

Simple Propagation Behavior: Day/Night

- Since CF is dependent on UV radiation level, maximum propagation frequencies **follow the sun across the earth**. The fact that F2 layer recombination of electrons and ions is slow, allows night-time propagation to occur at reduced frequencies. DX openings occur to Europe in the CONUS morning hours and to Asia in the CONUS evening hours. Similar day/night behavior is seen across CONUS..

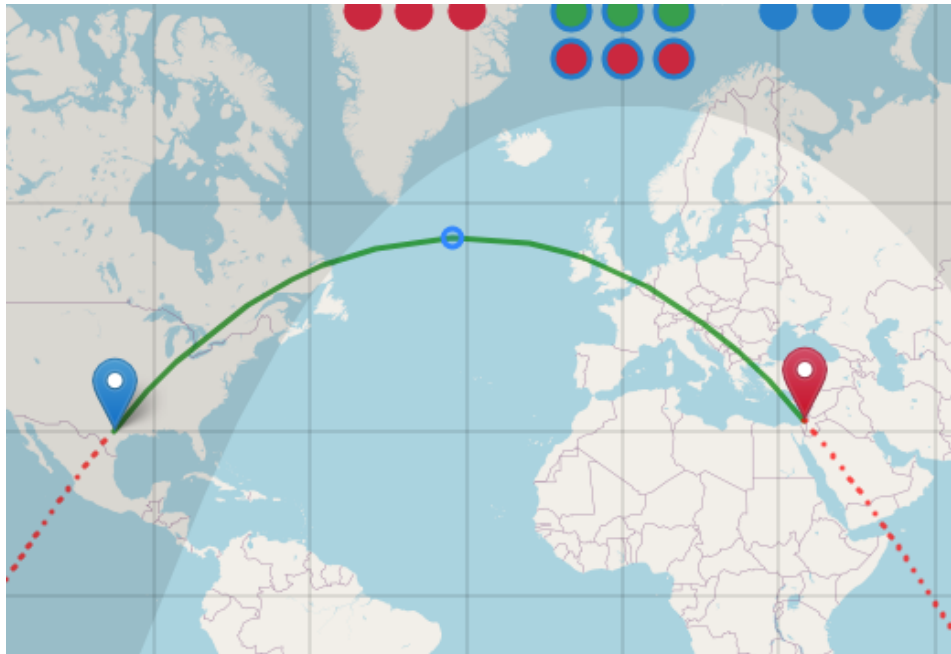

Simple Propagation Behavior – page 3

- The TOA's generated by antennas, previously discussed, generates a range of vertical elevation angles that will allow varying range circuits to be excited as long as the MUF requirement is met.

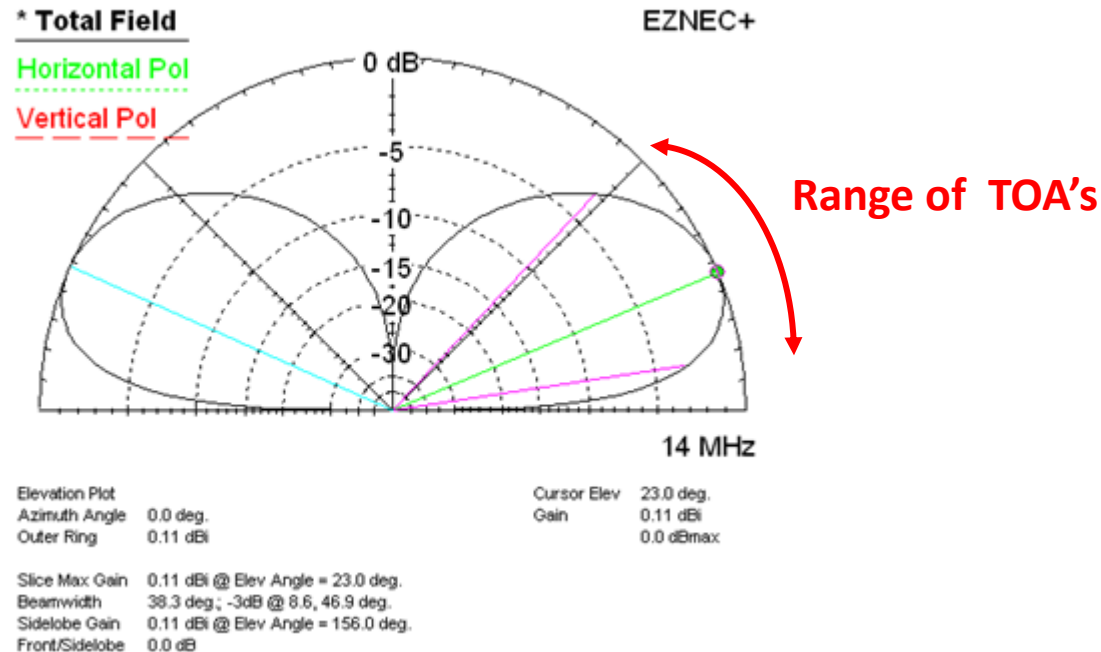

Propagation Behavior - Example

- For example, a 14 MHz signal, generated by a vertical in central Texas, can be heard in Florida and beyond, but not in Houston or San Antonio unless the MUF at the mid-point location exceeds 14 MHz (unlikely). For the present cycle 25 conditions, dropping down to maybe 30m and certainly 40m frequencies would allow good communications at these shorter ranges.

VOACAP Modeling Program

- The most accurate HF sky-wave propagation programs all use forms of VOACAP (Voice of America Coverage Analysis Program). This program was developed by the US Government at considerable expense but is available free.
- Attempts to include Ionosonde data into VOACAP have so far been unsuccessful.
- VOACAP does not work well for NVIS propagation.
- VOACAP is available at: <https://www.voacap.com/hf/>
 - Select VOACAP Online For Ham Radio

VOACAP For Ham Radio

(<https://www.voacap.com/hf/>)

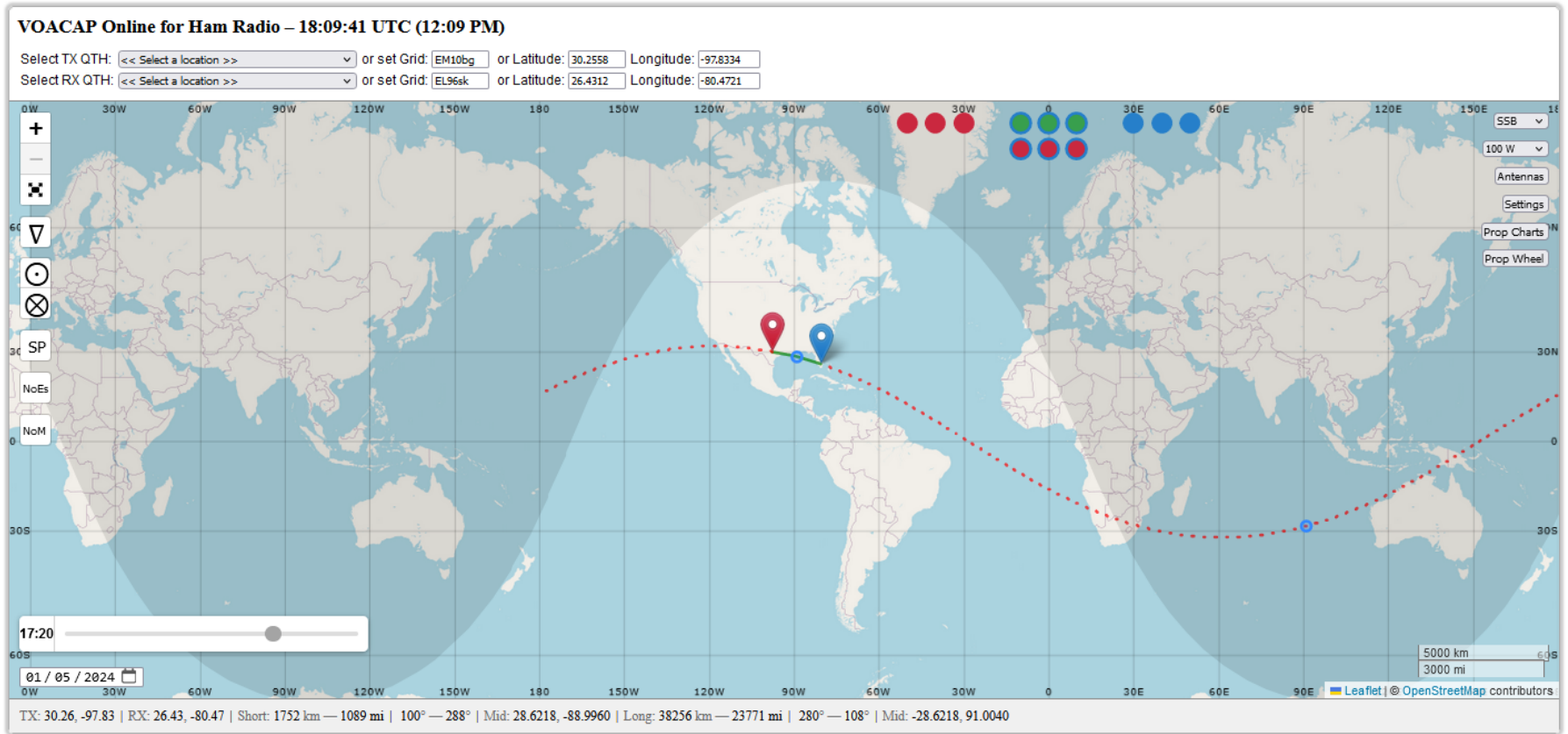

- Band-by-band
- REL | SDBW | SNR
- Best FREQ
- Total
- Year
- QSO Window
- Antenna
- TO Angle
- Planner
- Planner DIY
- P2P Grayline
- REL Map
- SDBW Map
- DXCC Grayline
- Space WX
- EME

VOACAP Input Variables – Location & Mode

Select TX QTH: << Select a location >> or set Grid: EM10bg or Latitude: 30.2558 Longitude: -97.8334
Select RX QTH: << Select a location >> or set Grid: EL96sk or Latitude: 26.4312 Longitude: -80.4721

TX: 30.26, -97.83 | RX: 26.43, -80.47 | Short: 1752 km — 1089 mi | 100° — 288° | Mid: 28.6218, -88.9960 | Long: 38256 km — 23771 mi | 280° — 108° | Mid: -28.6218, 91.0040

Note: Use negative sign for South Latitudes and West Longitudes.
Use pull-down location menu or Grid locations for easiest entry or drag red and blue markers to approximate locations.

**Mode
Input**

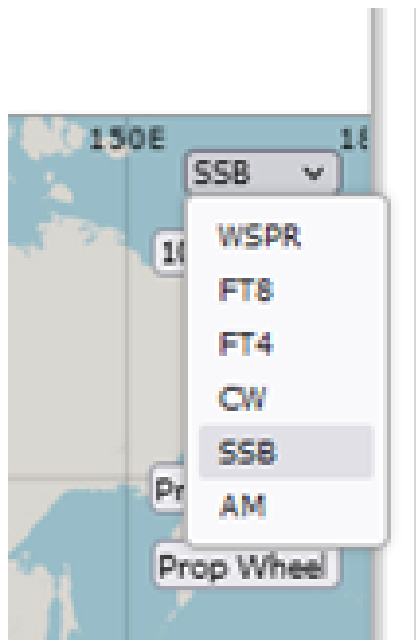

VOACAP Input Variables – Antennas

TX antennas:

10M: ▼

12M: ▼

15M: ▼

17M: ▼

20M: ▼

30M: ▼

40M: ▼

60M: ▼

80M: ▼

TX Antenna Abbreviations

- ISOTROPE = Isotrope, 0 dBi gain
- HVD025 = Half-Wave Vertical Dipole, feed at 0.25wl AGL
- V14 = 1/4 wl Vertical, with Average Ground
- V14GD = 1/4 wl Vertical, with Good Ground
- V32 = 3/2 wl Vertical, with Average Ground
- V58 = 5/8 wl Vertical, with Average Ground
- DxxM = Horizontal Half-Wave Dipole at xx meters AGL
- 3ELxxM = Horizontal 3-element Yagi at xx meters AGL
- 5ELxxM = Horizontal 5-element Yagi at xx meters AGL
- 8ELxxM = Horizontal 8-element Yagi at xx meters AGL

 Receiver Site

RX antennas:

10M: ▼

12M: ▼

15M: ▼

17M: ▼

20M: ▼

30M: ▼

40M: ▼

60M: ▼

80M: ▼

Swap TX/RX antennas

VOACAP Input Variables – Settings

Get SSN from SolarHams.org

General Propagation Settings

Noise: SSN: Dyn SSN?

Method: Min.TOA: °

Coverage Area Map Settings

Band: UTC: Range: hrs

Propagation Planner Settings

DX sites: CQ Zones DXCC Asia
 ITU Zones DXCC Europe
 DXCC All Continents DXCC North America
 DXCC Africa DXCC Oceania
 DXCC Antarctica DXCC South America

TX Antenna Analysis Settings

Sets: Dipoles Vertical vs ants @10m AGL
 Verticals, high dipoles Vertical vs ants @20m AGL
 3-el Yagis Vertical vs ants @40m AGL
 5-el Yagis Vertical vs ants @60m AGL
 8-el Yagis

Take-off Angle Analysis Settings

Period: Year Month

VOACAP Output – Prop Wheel

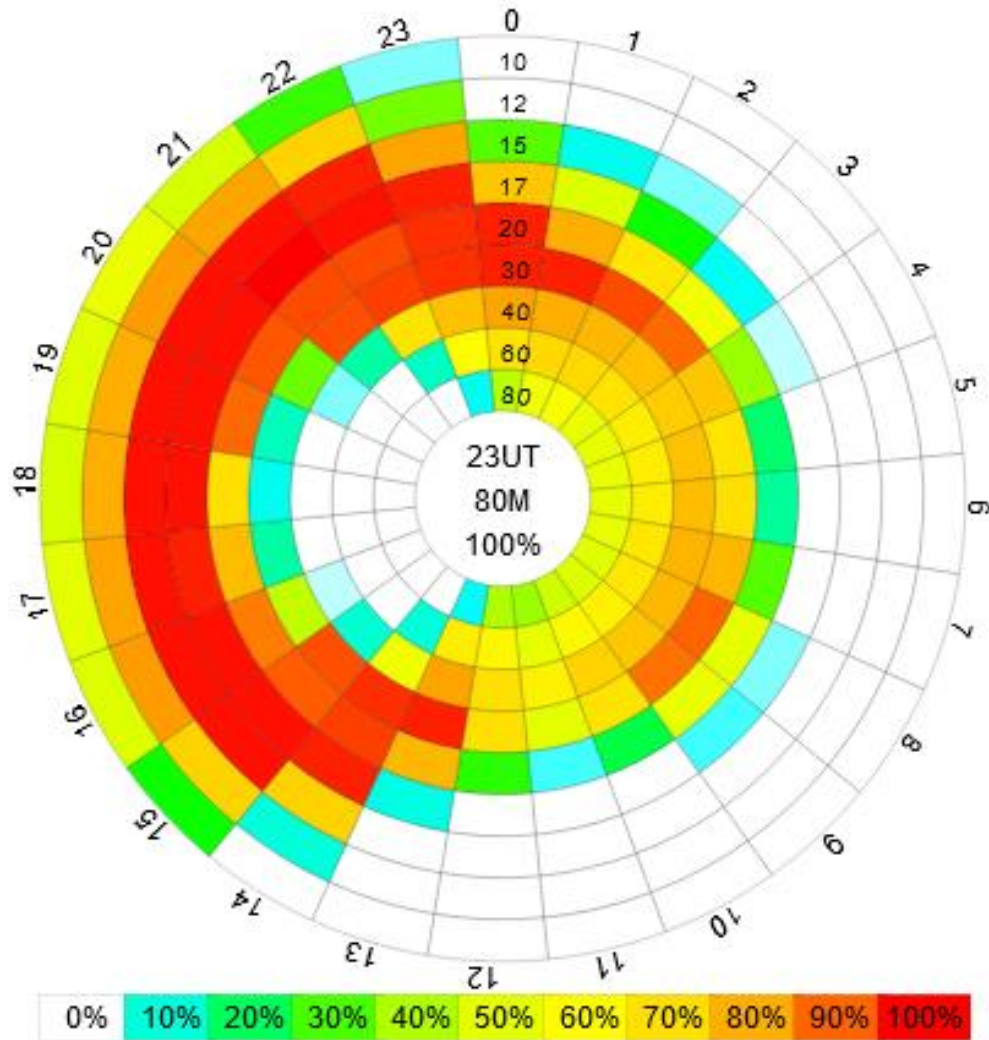

Bottom Button - REL | SDBW | SNR

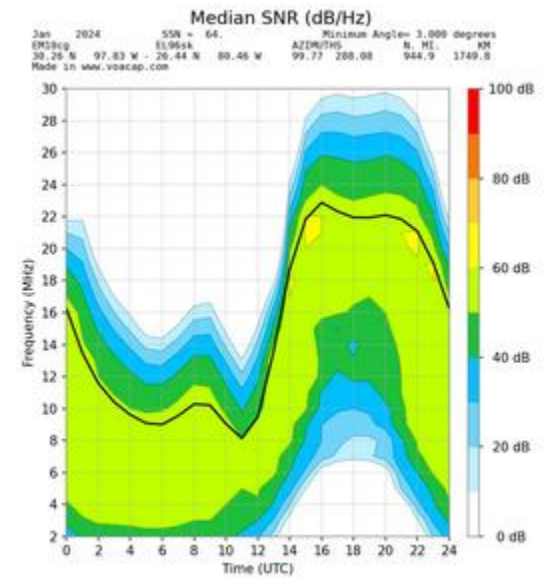
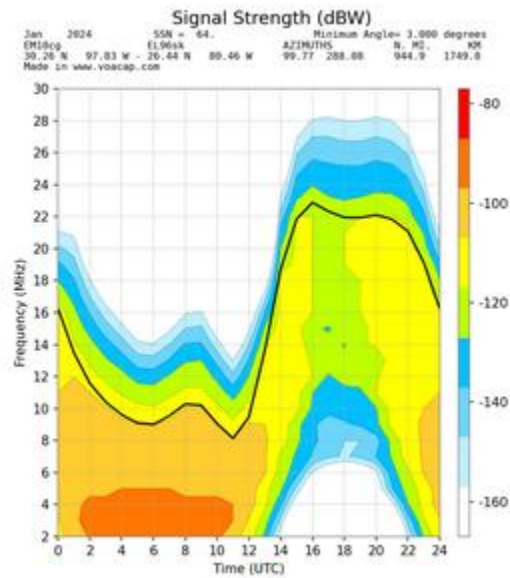
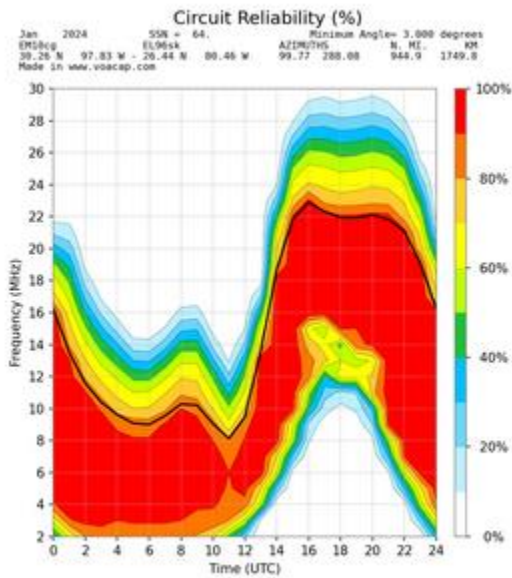

Circuit Reliability

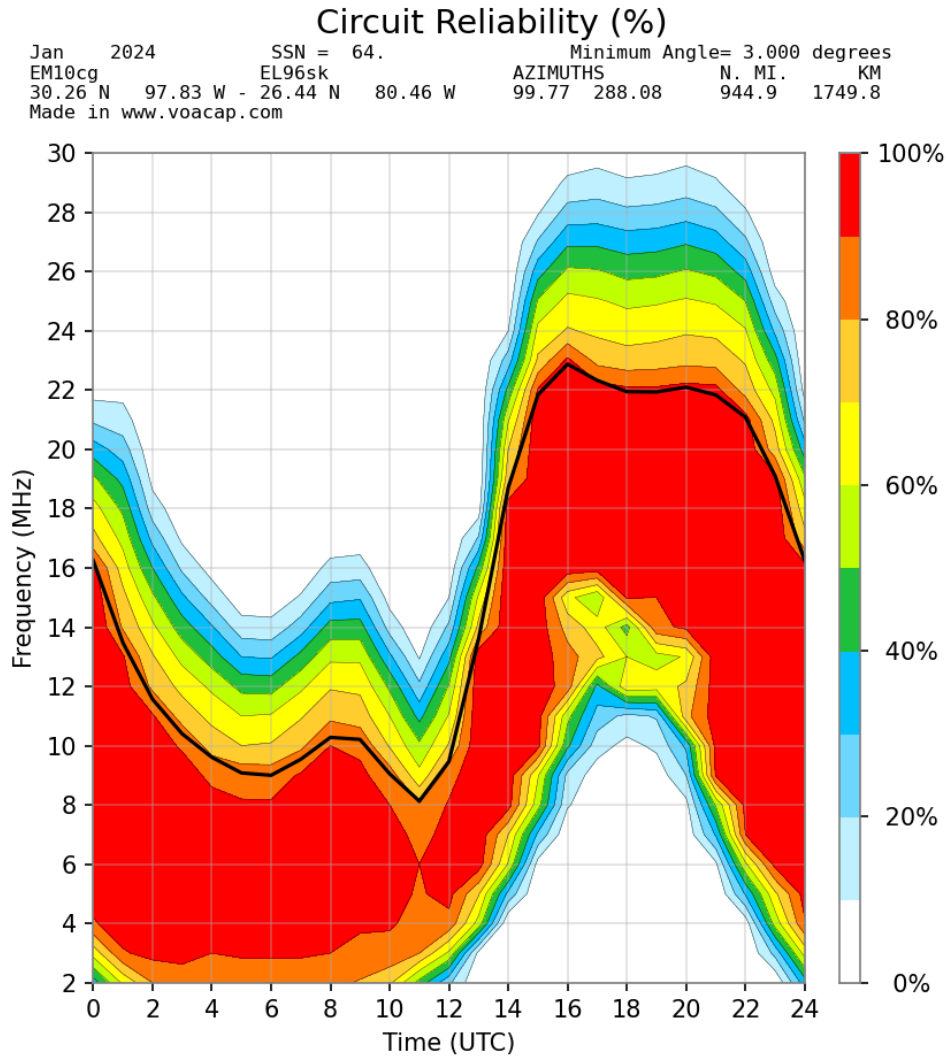

Receive Coverage Map

TX: EM10BG (30.26N, 97.83W) • Jan, 18 UTC, SSN:64, 14.1 MHz • 80 W, Mode: SSB
TX Ant: V14VYGD.ANT, -1.0°, RX Ants: V14GD.ANT. Noise: -153 dBW
Made in www.voacap.com, 2024-01-05

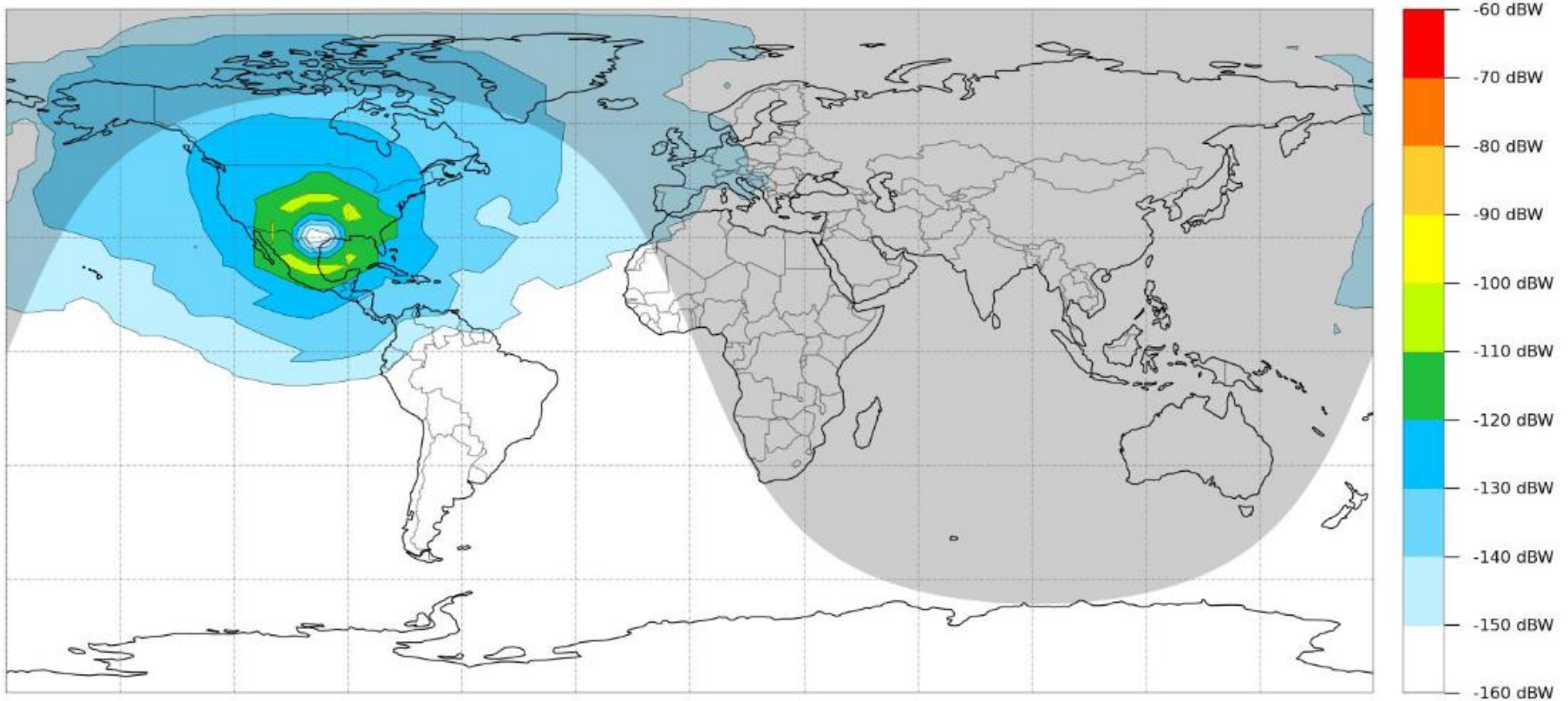

Transmit Coverage Map

TX: EM10BG (30.26N, 97.83W) • Jan, 18 UTC, SSN:64, 14.1 MHz • 80 W, Mode: SSB
TX Ant: V14VYGD.ANT, -1.0°, RX Ants: V14GD.ANT. Noise: -153 dBW
Made in www.voacap.com, 2024-01-05

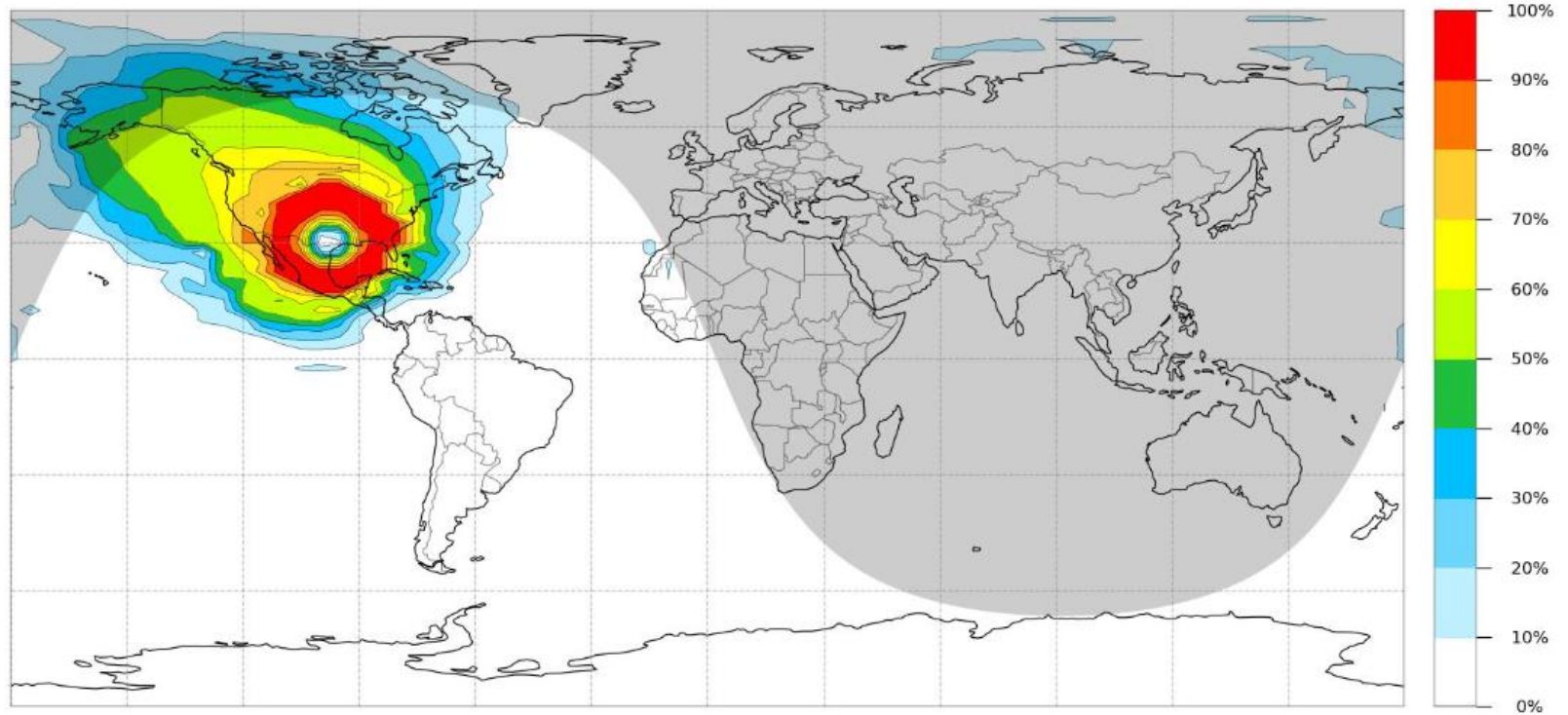

Comments on Example

- For this prediction run:
 - Path (Austin to southern Florida) is open with 90% 100% reliability from 1300Z through 2300Z on frequencies from 30 m to 15 m for SSB, 100 watts with vertical antennas.
 - Note the solar terminators.
 - VOACAP assumed solar weather is shown on the next page.

VOACAP - Space Weather

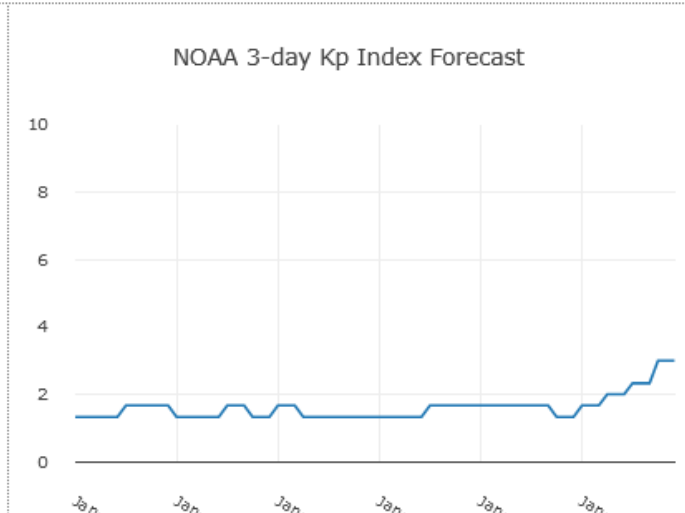
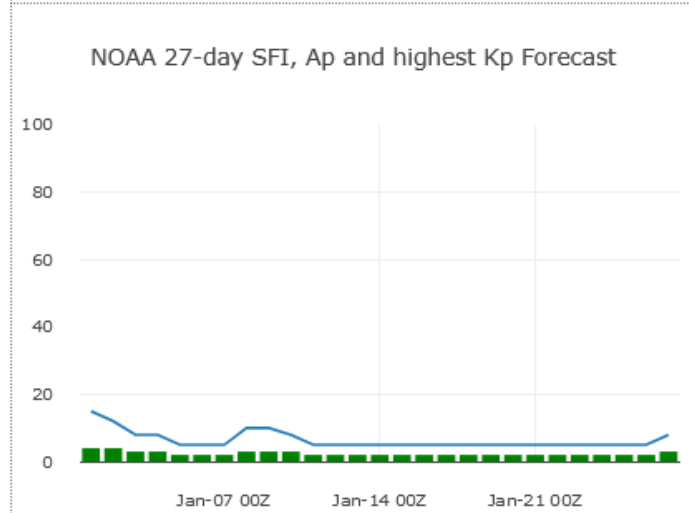
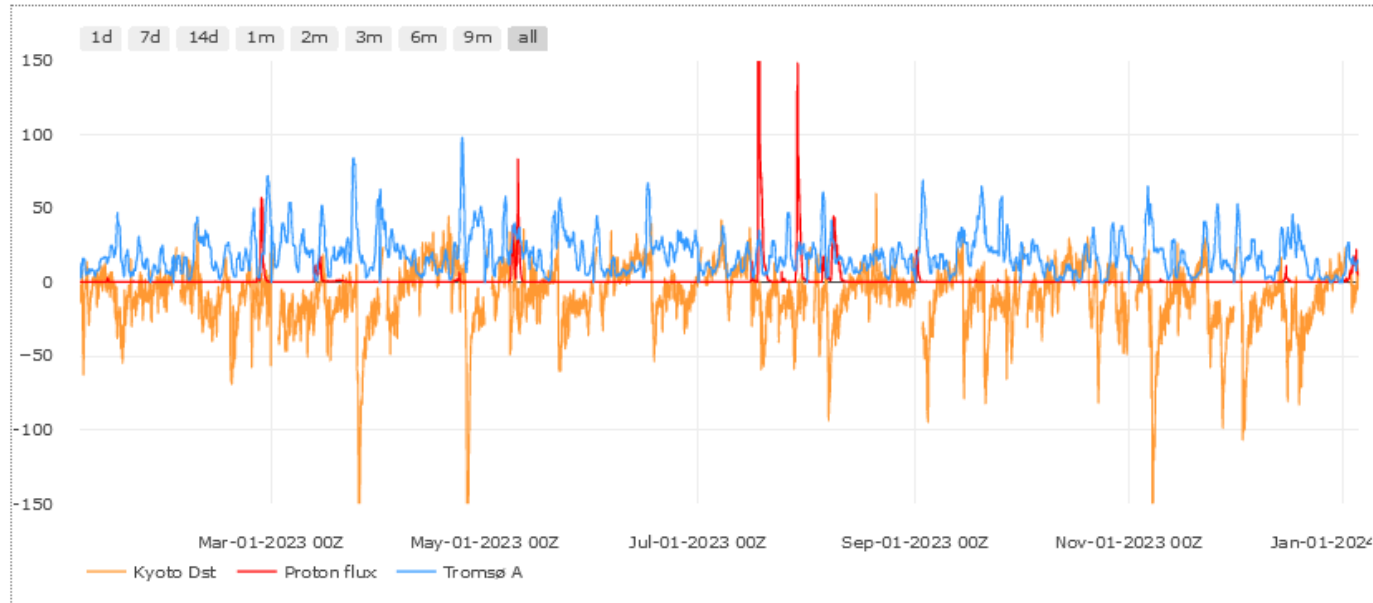

Accuracy Of VOACAP

- The accuracy of VOACAP was evaluated by me in 2022 using the NCDXF international beacon system.
- I found good agreement between NCDXF beacon reception at my QTH and VOACAP.

Propagation Beacons

- I found that reverse propagations networks like Reverse Beacon, PSK Reporter or WSPR difficult to use scientifically since the locations of the receiving stations was not well documented and varied in time.
- Therefore, the NCDXF/IARU Beacon Network was used to evaluate the accuracy of VOACAP.

NCDXF/IARU Beacon Network

- Worldwide network of high-frequency radio beacons that transmit on 14.100, 18.110, 21.150, 24.930, and 28.200 MHz.
- The [NCDXF](#) (Northern California DX Foundation), in cooperation with the [IARU](#) (International Amateur Radio Union), constructed and operates the network.
- The entire system is designed, built and operated by volunteers at no cost to users.

NCDXF Beacons

<https://www.ncdxf.org/pages/beacons.html>



Off due to hardware failure. The operators are working on the problem. Please be patient.

Transmission Pattern

- Each of the 18 beacons transmits once on each band once every three minutes, 24 hours a day.
- A transmission consists of the callsign of the beacon sent at 22 words per minute followed by four one-second dashes.
- The callsign and the first dash are sent at 100 watts. The remaining dashes are sent at 10 watts, 1 watt and 100 milliwatts.
- At the end of each 10 second transmission, the beacon steps to the next higher band and the next beacon in the sequence begins transmitting.
- See: <http://www.ncdxf.org/beacon/index.html> for real-time display of frequency, station location UTC time.

HF Beacon Monitor Program - Faros

- See: <http://www.dxatlas.com/Faros/>
- Cost - \$25.00
- Scans and records signals from all received NCDXF Beacons.
- Evaluates quality and accuracy of reception using computed time delays for each station.
- Writes all beacon information to a permanent file.
- Should download and install the latest Beacon List as locations do change.

Hardware System



Audio – Line in

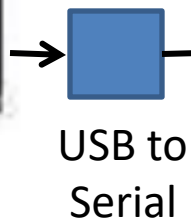

USB to
Serial



ICOM CT-17

CI-V

GAP Titan DX
Vertical Dipole

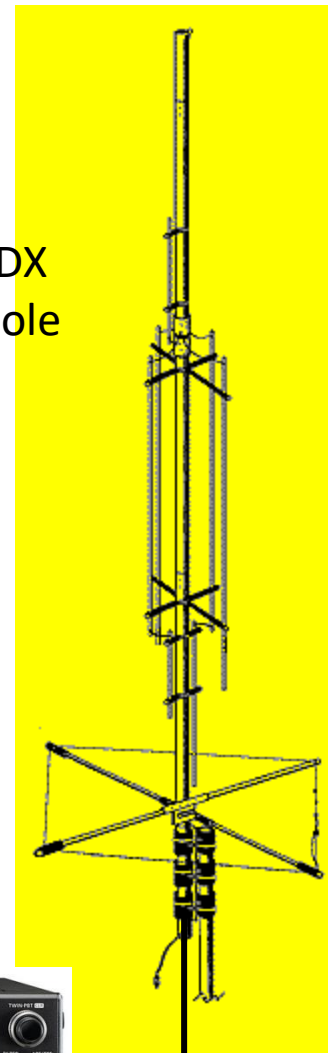

Fixed
Audio out



W10 Desktop



ICOM IC-7610

Log File Structure

Sample Log File

```
;DATE=2006-04-01      LAT=7911      LON=-14304
;UTC--MHZ--Call--SNR,dB--QSB,%--Evidence--Delay,ms
00:00:00      14      4U1UN      0.0      65      2.47      26
00:00:10      14      VE8AT      -8.2      100      0.14      32
00:00:20      14      W6WX      1.8      62      2.34      25
```

Record Structure

Each record in the log file represents a single observation of the beacon transmission in a 10-second slot. The record consists of 7 tab-separated fields, followed by a CR/LF code. Tab-separated data can be easily imported into MS Excel, MS Access and many other data management programs. The following fields are included in a record:

- **UTC** - the time of observation, UTC;
- **MHZ** - the band, in MHz;
- **Call** - the callsign of the beacon;
- **SNR** - the SNR, in Db, of the signal. The SNR is defined here as the ratio of key-down signal to average noise level, in the absence of signal, in an effective noise bandwidth of 100 Hz. See the following paper for a discussion of the SNR definition:
[The Weak-Signal Capability of the Human Ear. Ray Soifer, W2RS. Proceedings of the 36th Conference of the Central States VHF Society.](#)
- **QSB** - the QSB index, defined as the fraction of time on a scale from 0% to 100% during which the signal was below the noise;
- **Evidence** - a measure of probability that the received signal was transmitted by the beacon, on a logarithmic scale. The detection threshold is **Evidence = 1**.
- **Delay** - the interval, in milliseconds, between the start of the 10-second time slot and the moment when the signal appeared in the audio data. This interval includes the hardware latency of the transmitter and receiver, and the ionospheric propagation delay.

Beacon Reception

11 Jan 2024

- SSN = 151
- SFI = 193
- Kp = 2, 3 (quite geomagnetic field)
- Note: Legion

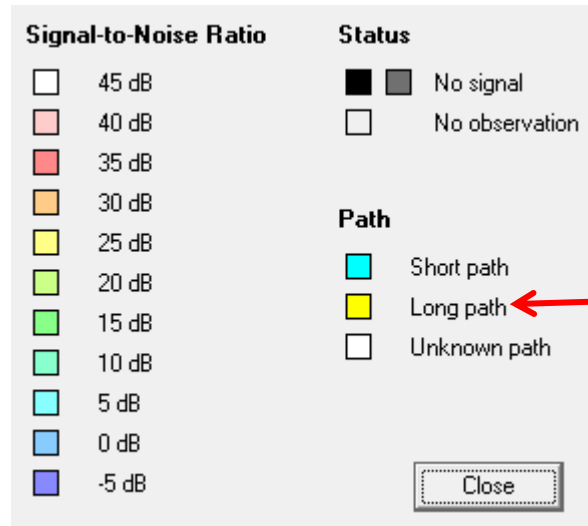

Beacon Received – 11 Jan. 2023

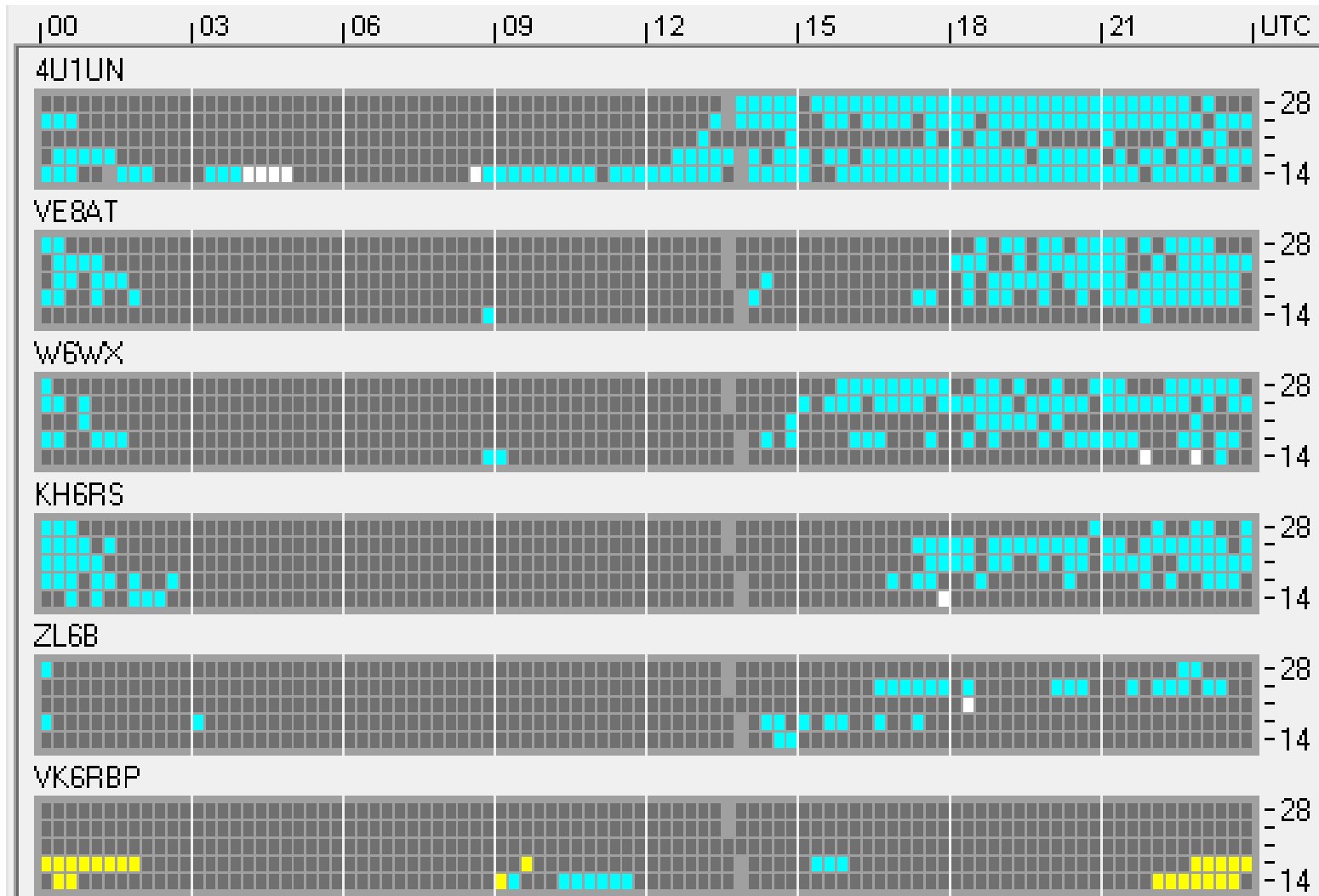

Beacon Received – 11 Jan. 2023

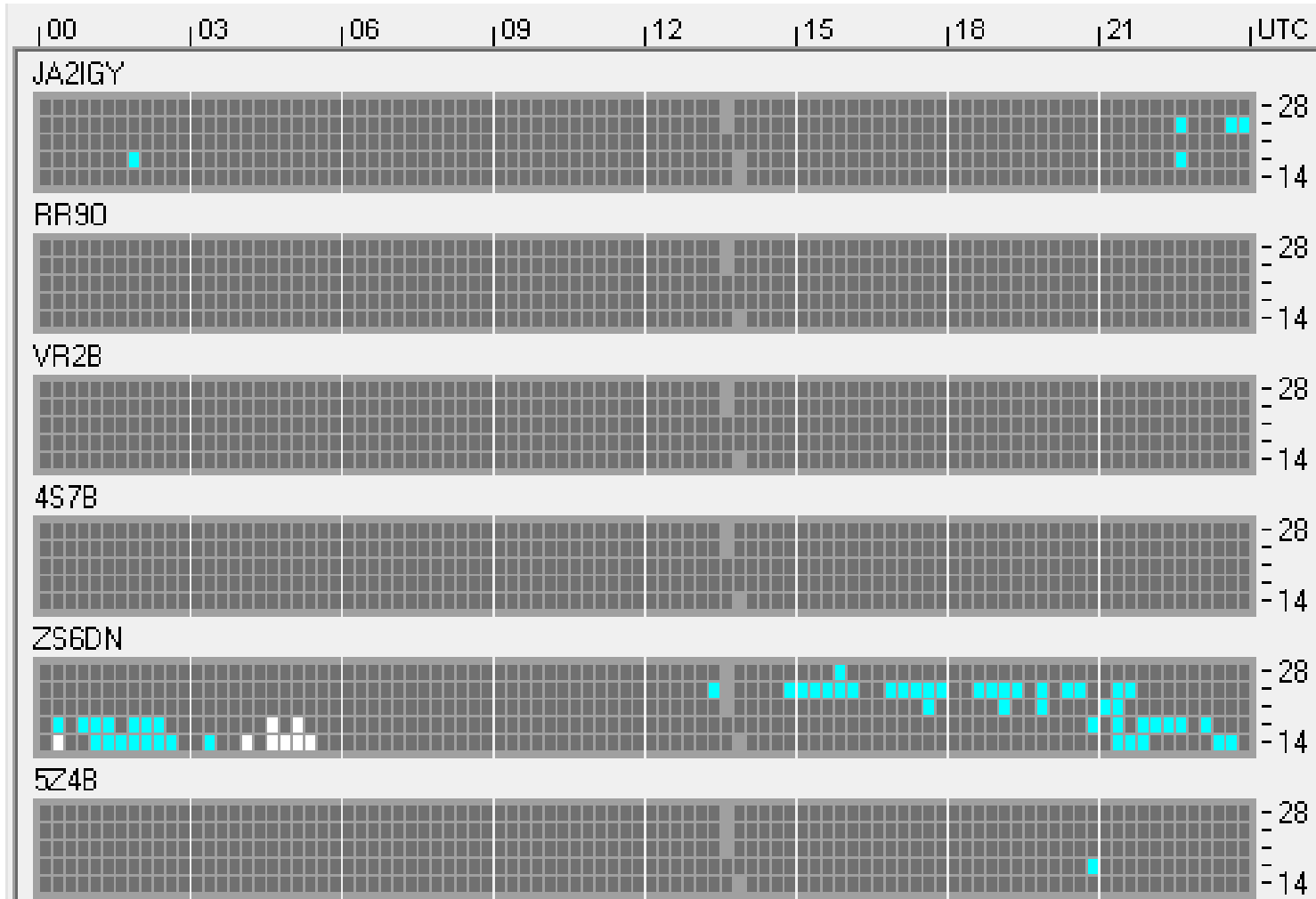

Beacon Received – 11 Jan. 2023

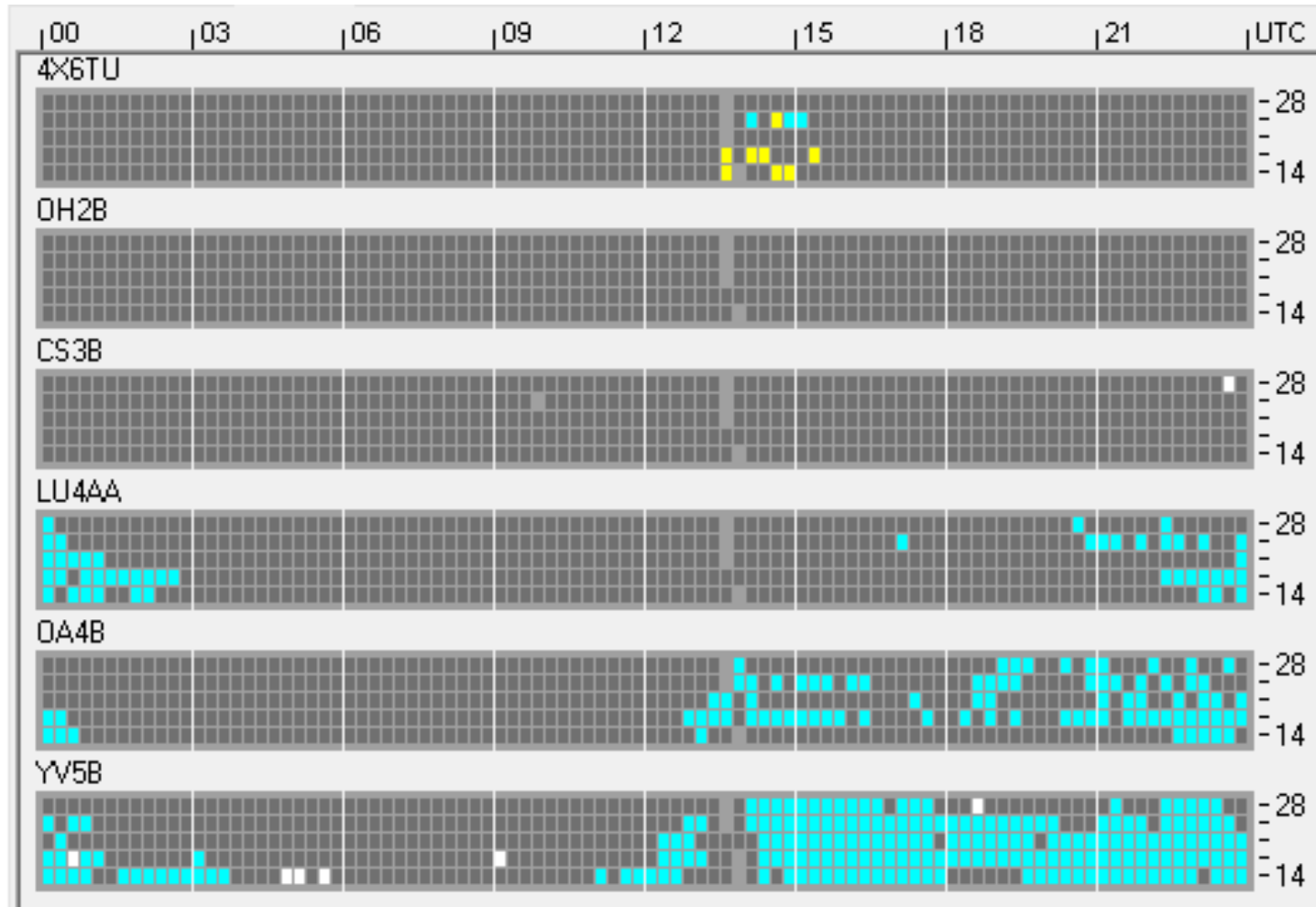

Western Australia Long Path

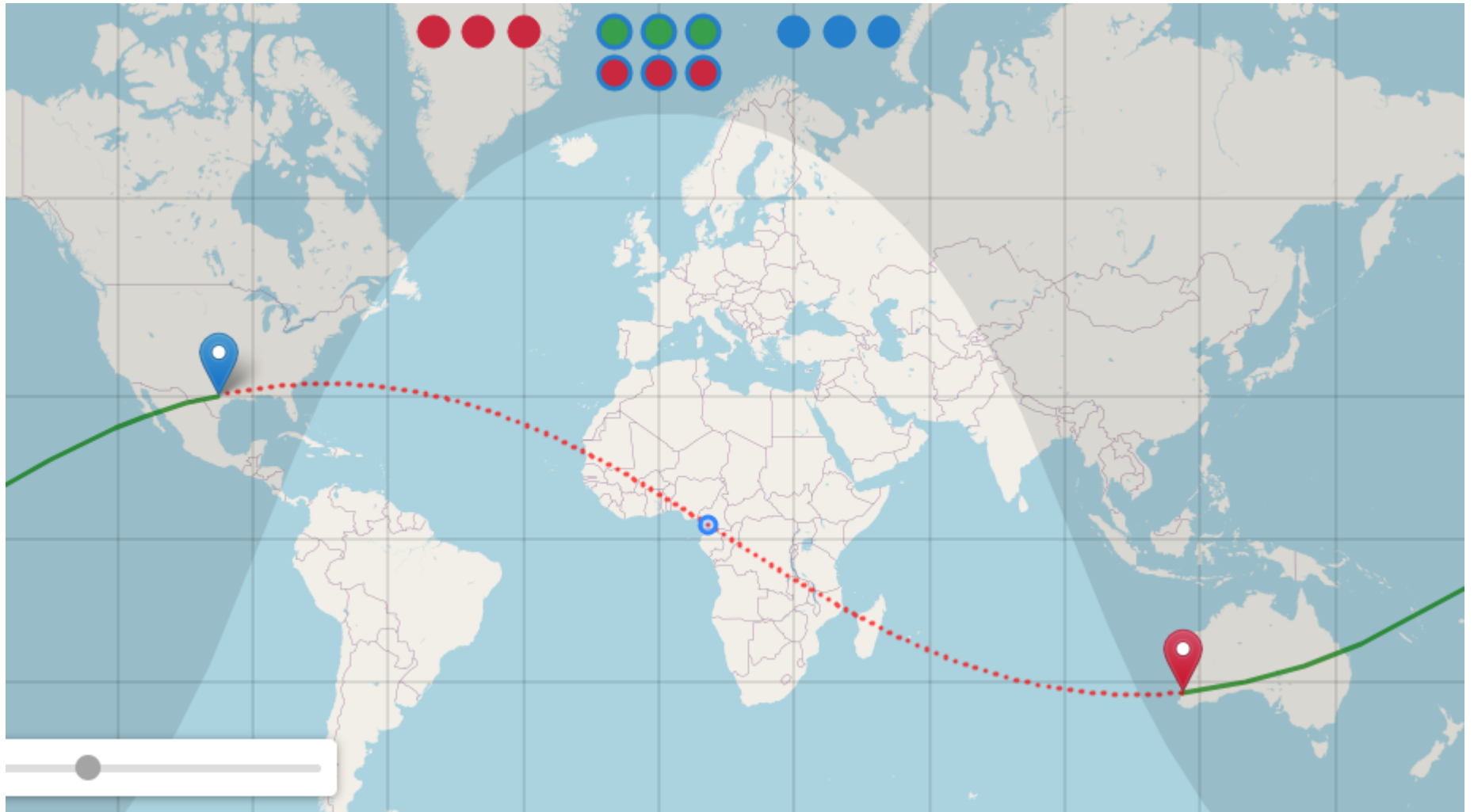

VK6RBP Long Path

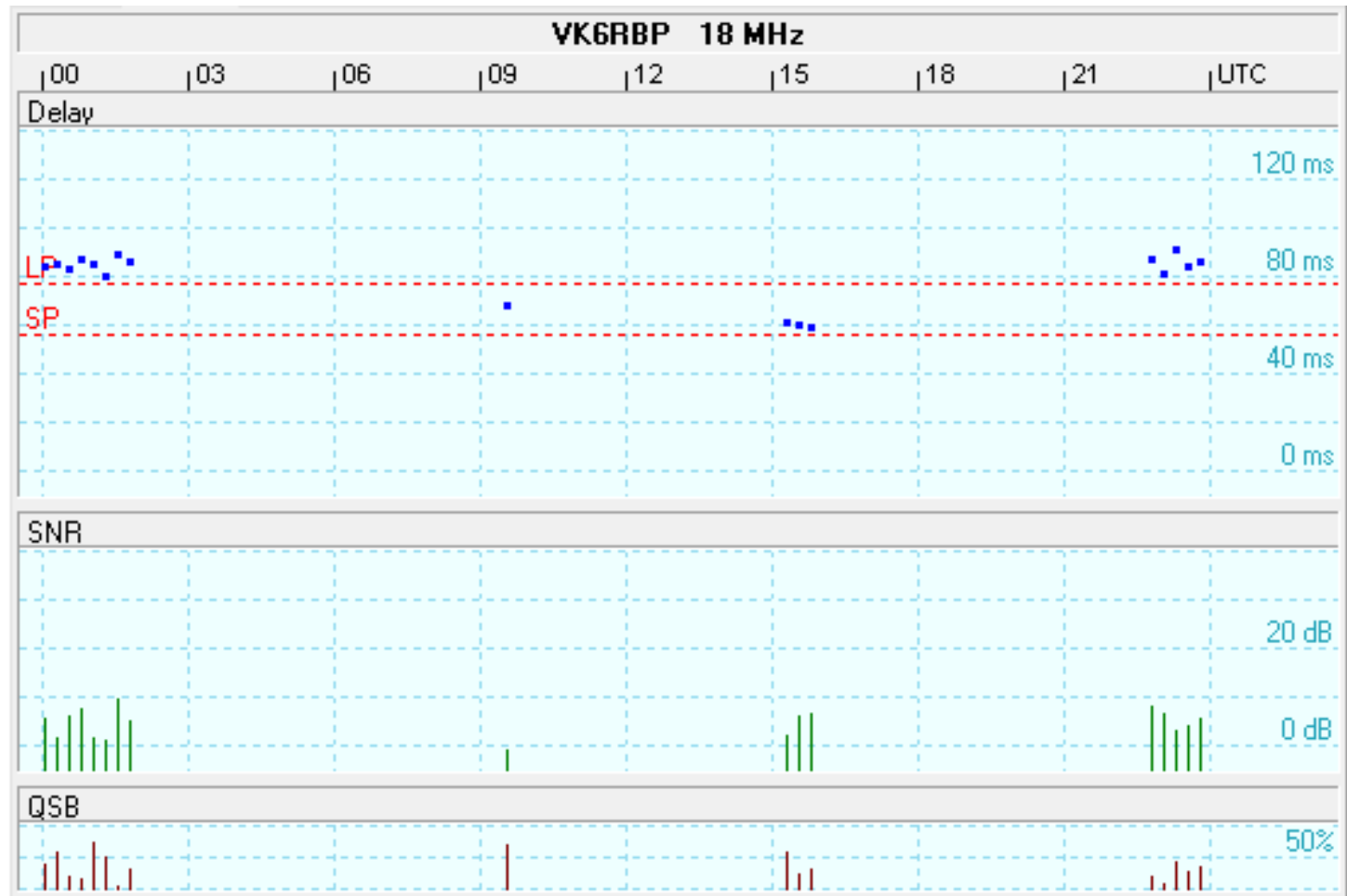

Western Australia – Prop wheel

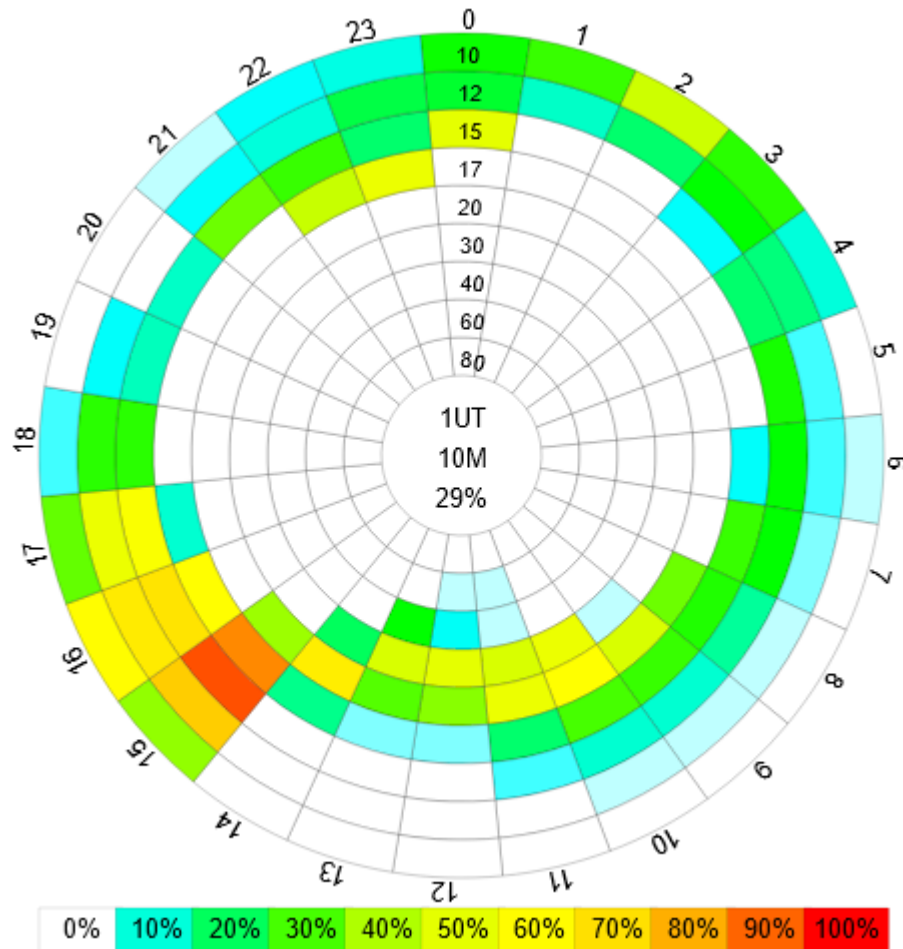

Propagation Path – VOACAP

Israel

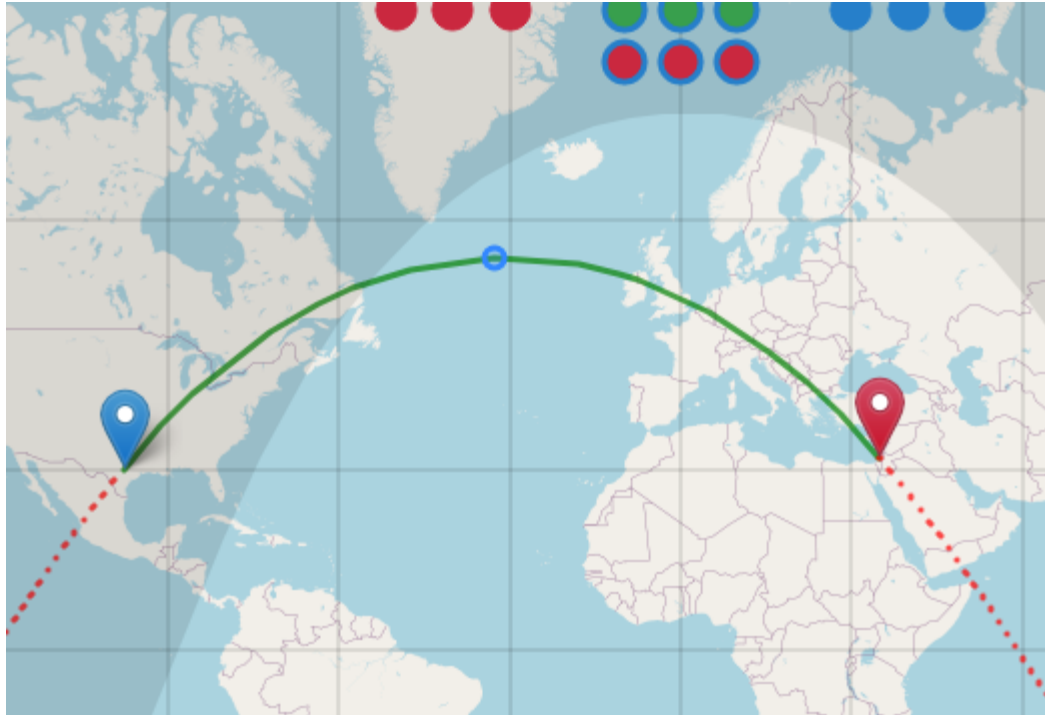

4X6TU (Israel)



Prop Wheel for Israel

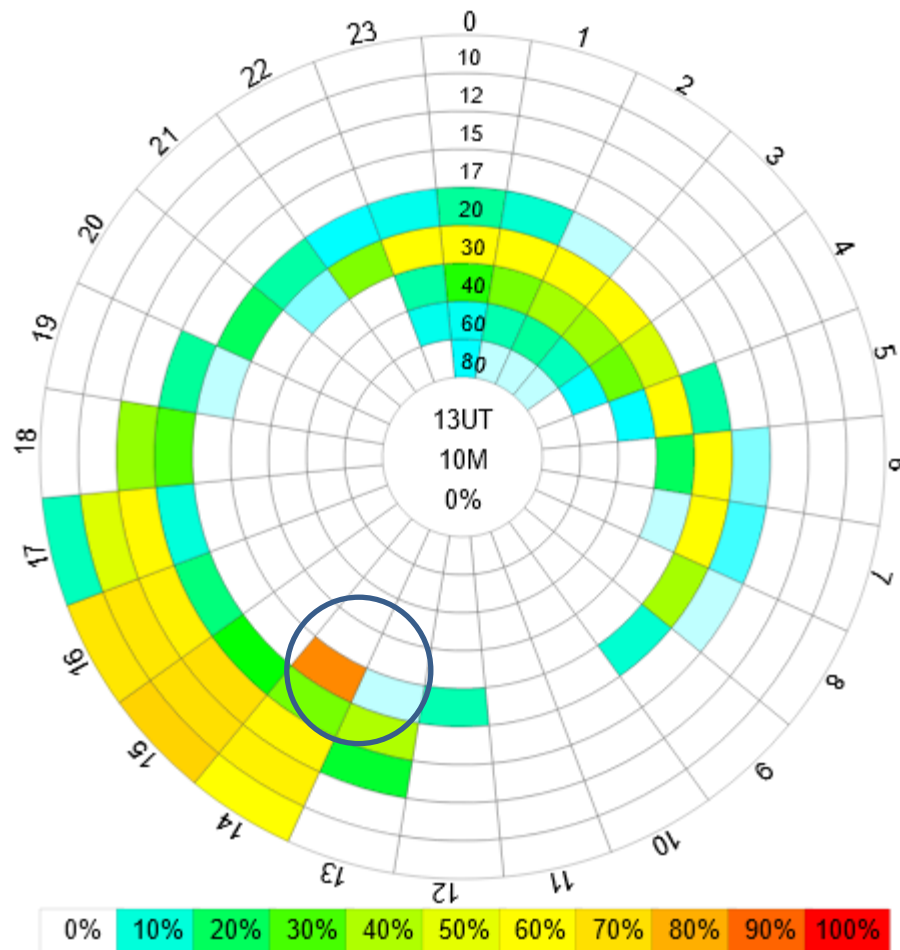

Conclusions from 2024 Study

- Note FAROS and VOACAP path discrepancies for Western Australia and Israel.
- VOACAP did not report the Long Path propagation correctly as detected by FAROS.
- I suspect these propagation paths included multilayer hops may not be properly modeled in VOACAP.
- You can see the advantage of using the NCDXF Beacons!

SUMMARY

- HF propagation is complicated and best determined by reception of beacons (actual signals).
- Propagation programs, using VOACAP, do a good job during quiet geomagnetic conditions.
- Operate near the MUF for each circuit to minimize D-layer absorption and maximize signal strengths.
- Best propagation follows the sun, but do try long-paths if using a Yagi by turning 180° .

Questions?

Lewis Thompson – W5IFQ

**Senior Engineering Scientist, P.E.
Applied Research Laboratories,
University of Texas at Austin**

**Personal Cell – 512-587-9944
Home E-mail: w5ifq@att.net**